

GEAR PUMPS AND MOTORS “B” SERIES

GROUP 3

Technical catalogue

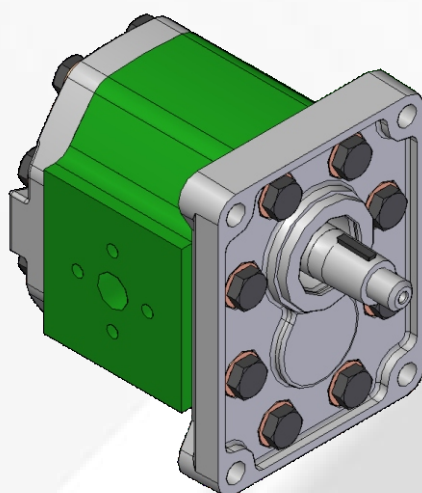

E0.17.0703.02.01

COMPANY
WITH QUALITY SYSTEM
CERTIFIED BY DNV
=ISO 9001/2000=

salam ™

Page 1 - GENERAL INDEX

Page 2 - Features - Quick guide

Page 3 - Features - General - Working conditions - Fire resistant fluid

Page 4 - Features - Drive shaft - Pump rotation direction - Hydraulic pipe lines

Page 5 - Features - Filtration index recommended - Tightening torque - Common formulas

Page 6 - Features - Identification label

Page 7 - Features - Changing rotation instructions

Page 8 - 3P/MB GROUP 3

Page 9 - Combination with types of flanges and drives shafts available

Page 10 - Assembling dimensions and values of pressure and speed

Page 11 - Version interchangeable with 3.5PC

Page 12 - Flanged ports

Page 13 - Flanged ports - Threaded ports

Page 14 - Drive shafts

Page 15 - Mounting flanges

Page 16 - Mounting flanges

Page 17 - Outrigger bearing

Page 18 - Rear covers

Page 19 - Rear cover for multiple pump 3PB/2PB

Page 19 - Rear cover with priority flow divider valves

Page 20 - Multiple gear pumps - Assembling dimensions

Page 21 - 3PB combination with 2PB(communicating inlet ports)/3PB/2PB with separated stages

Page 22 - 23 - 24 - Pump performance curves

Page 25 - 26 - Motor performance curves

Page 27 - Port connectors

Page 28 - How to order - Single pumps

Page 29 - How to order - Multiple pumps

Page 30 - WARRANTY

E0.17.1011.02.02

The data in this catalogue refers to the standard product.

The policy of Salami S.p.A. consists of a continuous improvement of its products. It reserves the right to change the specifications of the different products whenever necessary and without giving prior information.

If any doubts, please get in touch with our sales department.

QUICK GUIDE TO SELECT THE RIGHT PUMP SIZE

Definition of pressures

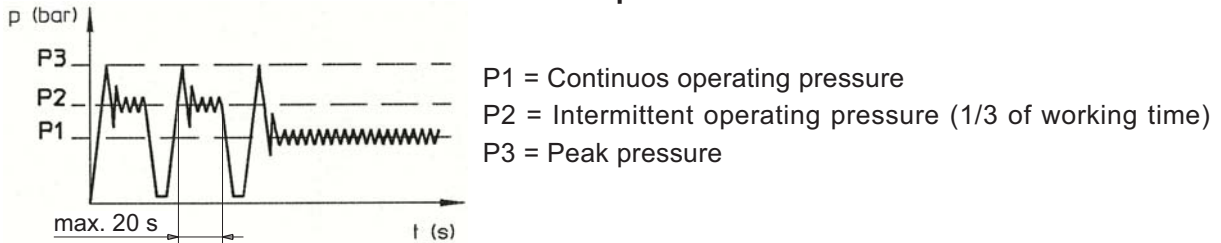

The diagram shown here below is used as a first dimensioning aid for the choice of pump group. It is based on the value of displacements (horizontal coordinates) and intermittent pressure $P2$ (vertical coordinates)

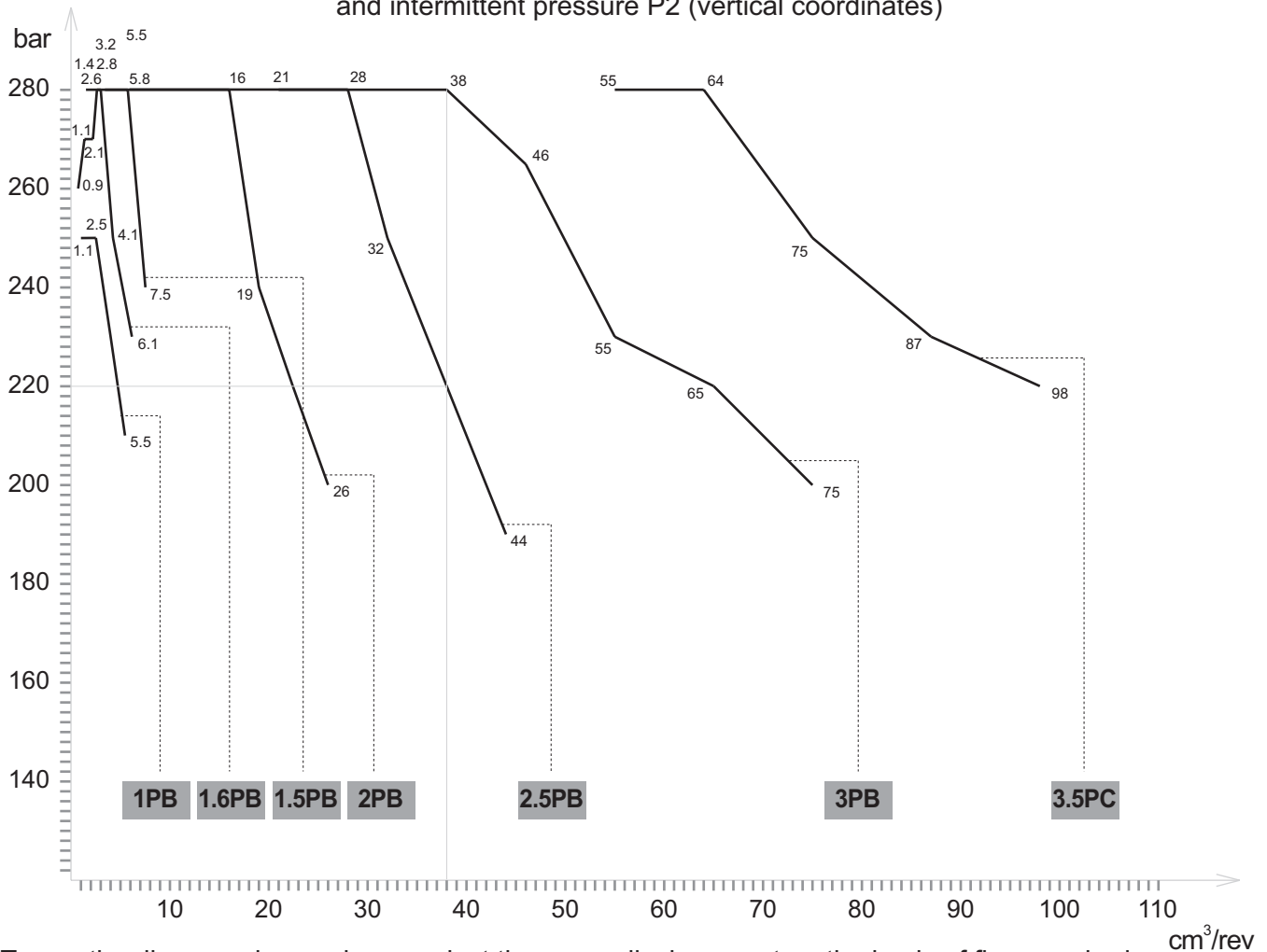

To use the diagram shown above, select the pump displacement on the basis of flow required. Then draw a vertical line to intersect the line representing the pump series. Now you can select the group on the basis of required application pressure.

Example: 38 cm^3/rev — 2.5PB 38 220 bar (3140 psi)
If required application pressure is more than 220 bar, use a 3 PB

GENERAL

SALAMI gear pumps and motors are available in seven series giving options of displacements from 1.1 cm³/rev to 98 cm³/rev (from 0.06 cu.in./rev to 6.03 cu.in./rev).

All pumps are available as multiple units either of the same or different series.

With all sizes of pumps and motors there are options of shafts, flanges and ports as for European, German and American standards.

SALAMI gear pumps and motors offer:

- High volumetric efficiency by innovative design and accurate control of machining tolerances.
- Axial compensation achieved by the use of floating bushes that allow high volumetric efficiency throughout the working pressure range.
- DU bearings ensure high pressure capability.
- 12 teeth integral gear and shaft.
- Extruded alluminum body.
- Die cast alluminum cover and flange - cast iron rear.
- Double shafts seals in all pump series except Group 1.
- Nitrile seals as standard and viton seals in high temperature applications.

All pumps and motors are hydraulic tested after assembly to ensure the high standard performance required by SALAMI'S engineering.

WORKING CONDITIONS

THE VALUES OF PRESSURE ARE ABSOLUTE

- Pump inlet pressure	0,7 to 2,5 bar 10 to 36 <i>psi</i>
- Return pipe line continuos pressure for motors	MAX 2,5 bar - 36 <i>psi</i>
- Return pipe line intermit. pressure for motors	MAX 6 bar for 15 sec - 85 <i>psi</i>
- Return pipe line peak pressure for motors	MAX 15 bar - 215 <i>psi</i>
- Minimum operating fluid viscosity	12 mm ² / sec
- Max starting viscosity	800 mm ² / sec
- Suggested fluid viscosity range	17 - 65 mm ² / sec
- Fluid operating temperature range	-15 to +85 °C
- Hydraulic fluid	mineral oil

Important:

in case of assembling of pumps without shaft seals (eg. B2 - B3...), you have to keep the value of min. suction pressure (0.7 bar (abs)) in the vane between pump and coupling too.

Lower pressure can lead to suction of oil through the front flange (seat of the shaft without seal); this can damage seriously the pump.

FIRE RESISTENT FLUID

Type	Description	Max pressure	Max speed (rpm)	Temperature
HFB	oil emulsion with 40% water	130 bar/1880 <i>psi</i>	2500	3°C +65°C
HFC	Water glycol	180 bar/2600 <i>psi</i>	1500	-20°C +65°C
HFD	Phosphate esters		1750	-10°C +80°C

DRIVE SHAFT

Radial and axial loads on the shafts must be avoided since they reduce the life of the unit. Pumps driven by power take - off on engines must always be connected by placing an "Oldham" coupling or coupling having convex toothed hub. This is to ensure that inevitable misalignment during assembly is reduced to minimum.

PUMP ROTATION DIRECTION VIEWED AT THE DRIVE SHAFT

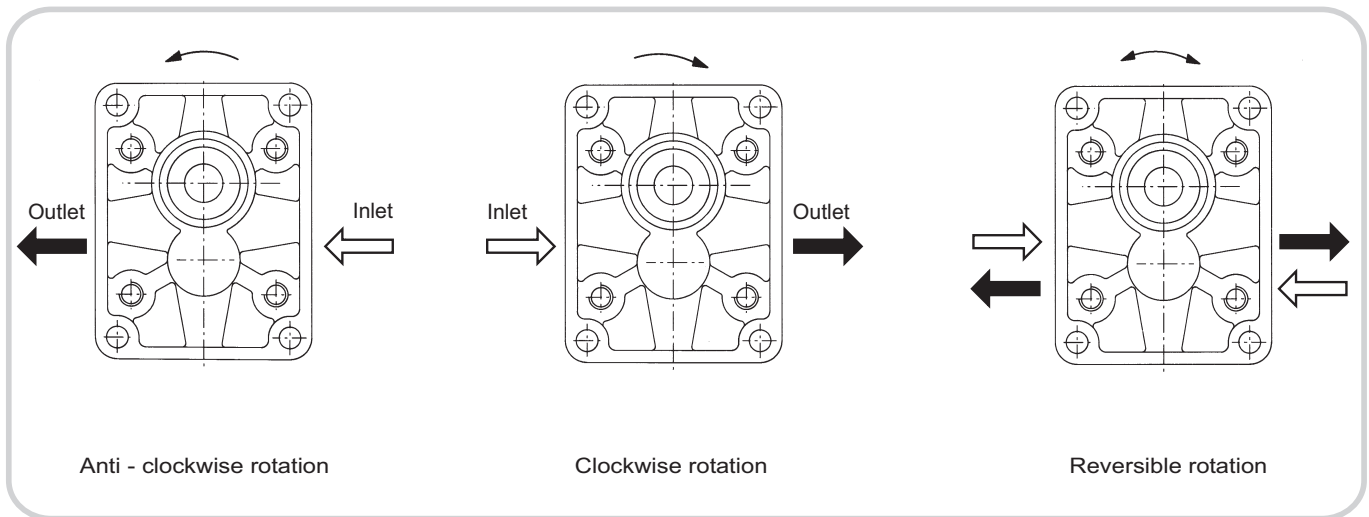

HYDRAULIC PIPE LINE

To ensure favorable suction conditions it is important to keep pressure drop in suction pipe line to a minimum value (see WORKING CONDITIONS).

To calculate hydraulic pipe line size, the designer can use; as an approximate guide, the following fluid speed figures:

From 1 to 2 m/sec on suction pipe line
From 6 to 10 m/sec on pressure pipe line

From 3.28 to 6.36 ft/sec on suction pipe line
From 19.7 to 32.8 ft/sec on pressure pipe line

The lowest fluid speed values in pipe lines is recommended when the operating temperature range is high and/or for continuous duty.

The highest value is recommended when the temperature difference is low and/or for intermittent duty.

When tandem pumps are supplied by 2 different reservoirs with 2 different fluids it is necessary to specify "AS" version.

In case of reversible motor allowance must be made to ensure the motor is not drained, through the case drain, when stationary.

FILTRATION INDEX RECOMMENDED

Working pressure	> 200 bar / 2900 psi	< 200 bar / 2900 psi
Contamination class NAS 1638	9	10
Contamination class ISO 4406	18/15	19/16
Achieved with filter $\beta_x = 75$	15 μm	25 μm

TIGHTENING TORQUE

OUR BOLTS AND TIE-RODS HAVE ALWAYS HEATING TREATMENT OF BLACK BURNISHING

PUMP TYPE		BOLT TYPE		TORQUE Nm	FOR SCREWS ZINC PLATED REDUCE TIGHTENING TORQUE OF 10%
SIZE	SERIE	DIAMETER	CLASS		
1	B SINGLE	M 8 x 1.25	8.8	20.5 - 25.5	
1	B MULTIPLE	M 8 x 1.25	8.8	20.5 - 25.5	
2	B SINGLE	M 10 x 1.5	8.8	47 - 51	
2	B MULTIPLE	M 10 x 1.5	10.9	50 - 55	
2.5	B SINGLE	M 12	8.8	70 - 75	
2.5	B MULTIPLE	M 12	10.9	75 - 80	
3	B	M 10	HEX. BOLT 10.9 HEX. SOCKET H.C.B. 12.9	47 - 51	
3.5	C	M 12	8.8	74 - 85	
3	H	M 14	10.9	BOLT 180 150 - 160 TIE ROD	

COMMON FORMULAS

$$C = \text{Input torque} = \frac{q \cdot \Delta p}{62.8 \cdot \eta_m} \text{ (Nm)}$$

$$P = \text{Input power} = \frac{q \cdot n \cdot \Delta p \cdot 10^{-3}}{600 \eta_m} \text{ (kW)}$$

$$Q = \text{Outlet flow} = \frac{q \cdot n \cdot \eta_v}{1000} \text{ (l/min)}$$

LEGENDA

Δp = Working pressure (bar)

q = Displacement (cm^3/rev)

n = Speed (min^{-1})

η_m = Mechanical eff. (0.92)

η_v = Volumetric eff. (0.95)

Description of the product identification label

Based on the firm certification ISO 9001 - UNI EN 29001, section 4.8 (identification and traceability of the product), we have adopted a new identification label starting from the 1st march 1995. Pls, see following example:

A			
B			
C		D	
E	salami	F	G

A = Product short description (VD8A/FDD/U4G).

B = Customer part number.

C = Salami part number (6235 0025 0).

D = Production batch (for Salami management)

E = Rotation sense (only for pumps).

F = Manufacturing date (see data sheet here below)

G = Progressive number of assembling.

Only for pumps 2PB and 2PZ (except triple 2PB) the identification product is marked on the top of the pump body as shown here below:

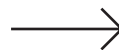

SALAMI 09/02
MADE IN ITALY 4010998
612271211 nr. 13
2PB 19S B25 B5

Product short description. _____
Salami part number and progressive number of assembling. _____
Production code (for Salami management). _____
Month and year of made: maybe in the future you can find this type of production date in the label beside too. _____
Rotation sense. _____

	1990	1991	1992	1993	1994	1995	1996	1997	1998	1999	2000	2001	2002	2003	2004	2005
JANUARY	0A	1A	2A	3A	4A	5A	6A	7A	8M	9M	0M	1M	2M	3M	4M	5M
FEBRUARY	0B	1B	2B	3B	4B	5B	6B	7B	8N	9N	0N	1N	2N	3N	4N	5N
MARCH	0C	1C	2C	3C	4C	5C	6C	7C	8P	9P	0P	1P	2P	3P	4P	5P
APRIL	0D	1D	2D	3D	4D	5D	6D	7D	8Q	9Q	0Q	1Q	2Q	3Q	4Q	5Q
MAY	0E	1E	2E	3E	4E	5E	6E	7E	8R	9R	0R	1R	2R	3R	4R	5R
JUNE	0F	1F	2F	3F	4F	5F	6F	7F	8S	9S	0S	1S	2S	3S	4S	5S
JULY	0G	1G	2G	3G	4G	5G	6G	7G	8T	9T	0T	1T	2T	3T	4T	5T
AUGUST	0H	1H	2H	3H	4H	5H	6H	7H	8U	9U	0U	1U	2U	3U	4U	5U
SEPTEMBER	0I	1I	2I	3I	4I	5I	6I	7I	8V	9V	0V	1V	2V	3V	4V	5V
OCTOBER	0J	1J	2J	3J	4J	5J	6J	7J	8Z	9Z	0Z	1Z	2Z	3Z	4Z	5Z
NOVEMBER	0K	1K	2K	3K	4K	5K	6K	7K	8X	9X	0X	1X	2X	3X	4X	5X
DECEMBER	0L	1L	2L	3L	4L	5L	6L	7L	8Y	9Y	0Y	1Y	2Y	3Y	4Y	5Y



Rotation changing instructions for pumps GROUP 2 - 2.5 - 3 - 3.5

Before starting, be sure that the pump is cleaned externally as well as the working area to avoid that particles dangerous for pump working can find their way into the pump.

Pump represented is aclockwise rotation pump.

To obtain an anti_clockwise rotation read carefully the following instructions.

Picture "A"

- 1 - Loosen and fully unscrew the clamp bolts.
- 2 - Lay the pump on the working area in order to have the mounting flange turned upside.
- 3 - Coat the shaft extension with grease to avoid damaging the shaft seal.
- 4 - Remove the flange and lay it on the working area; verify that the seal is correctly located in the body seat.

Picture "B"

- 1 - Mark the position of the bushing and eventually the thrust plate, relative to the body.
- 2 - Remove the bushing, thrust plate and the driving gear taking care to avoid driven gear axial shifts.

Picture "C"

- 1 - Draw out the driven gear from its housing, taking care to avoid rear cover axial shifts.
- 2 - Re-locate the driven gear in the position previously occupied by the driving gear.

Picture "D"

- 1 - Re-locate the driving gear in the position previously occupied by the driven gear.

Picture "E"

- 1 - Replace the bushing and thrust plate taking care that:
 - marks are located as on the picture
 - surface containing the seal is visible
 - seal and its protection are correctly located

Picture "F"

- 1 - Clean body and mounting flange refaced surfaces.
- 2 - Verify that the two plugs are located in the body.
- 3 - Refit the mounting flange, turned 180° from its original position.
- 4 - Replace the clamp bolts and tighten crosswise evenly to a torque of 40 - 45 Nm for 2PB, 2.5PB, 45 - 50 Nm for 3PB, 3.5PB.
- 5 - Check that the shaft rotates freely.
- 6 - Mark on the flange the new direction of rotation.

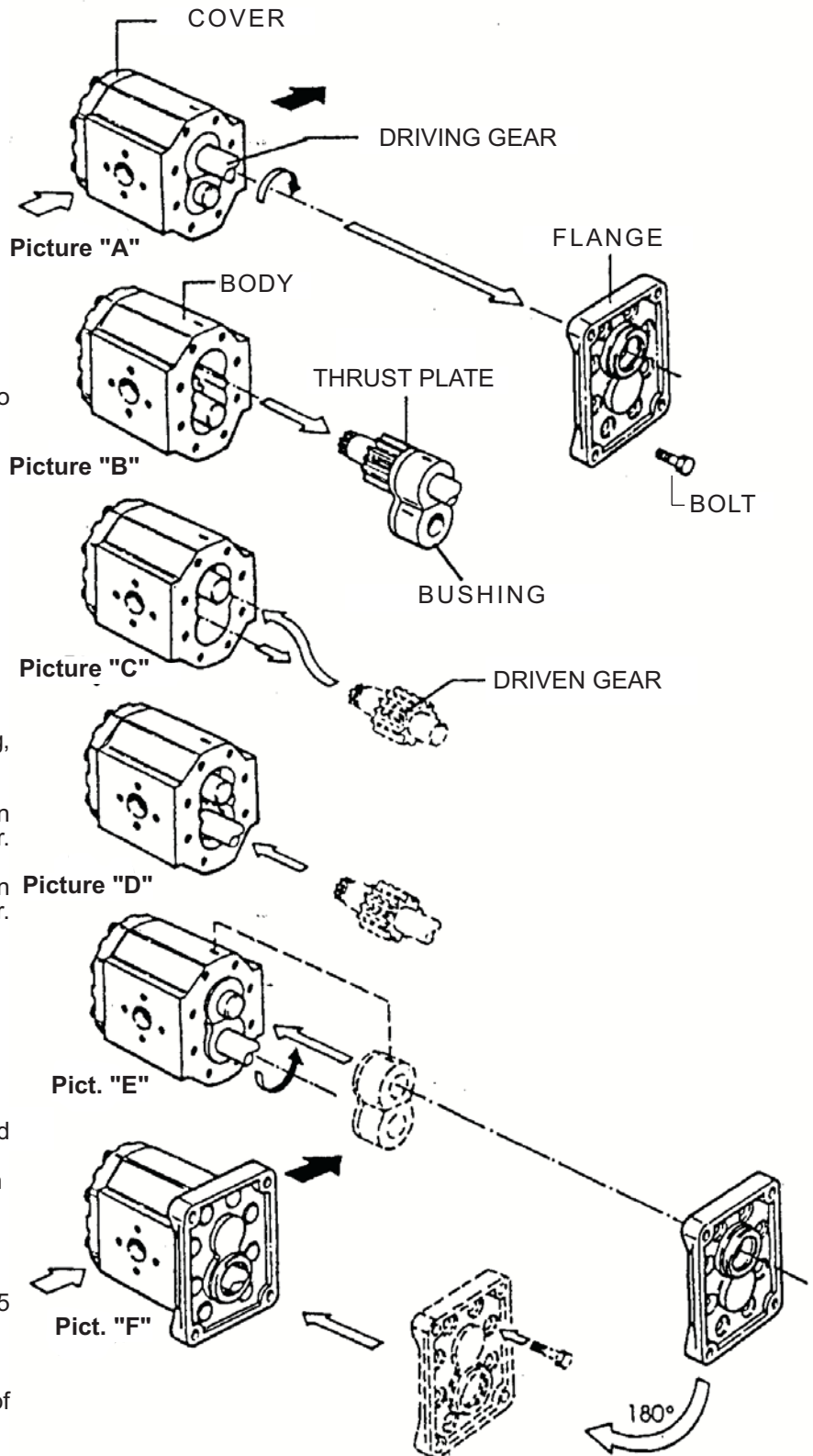

IMPORTANT: TO AVOID A PERFORMANCE LOSS DO NOT CHANGE MOTOR ROTATION

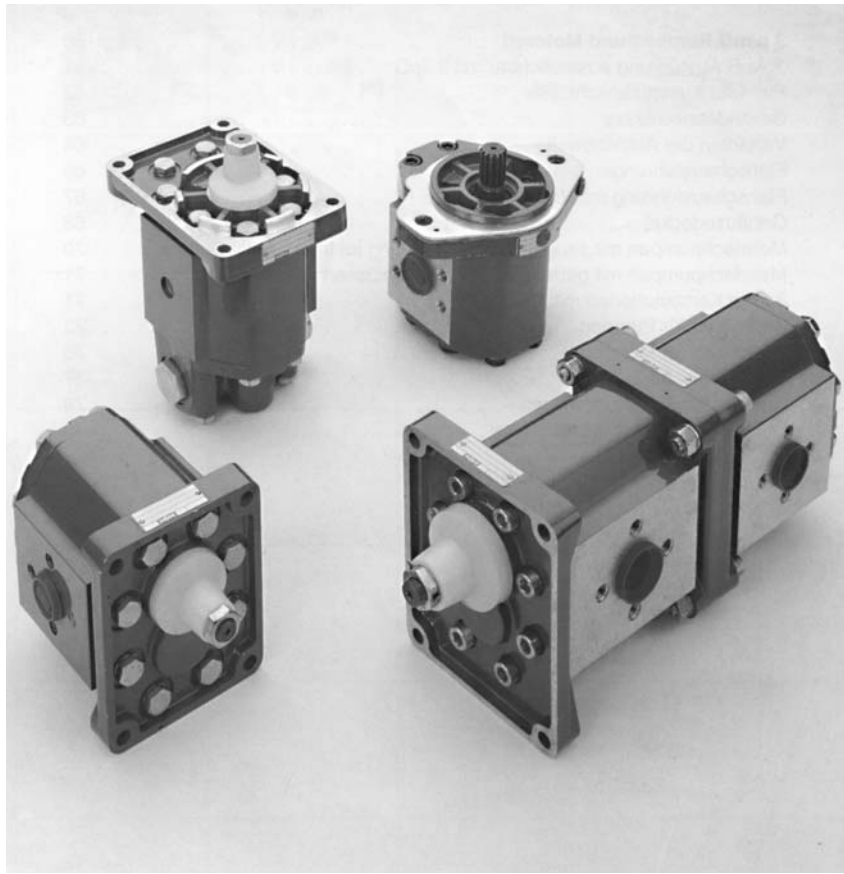



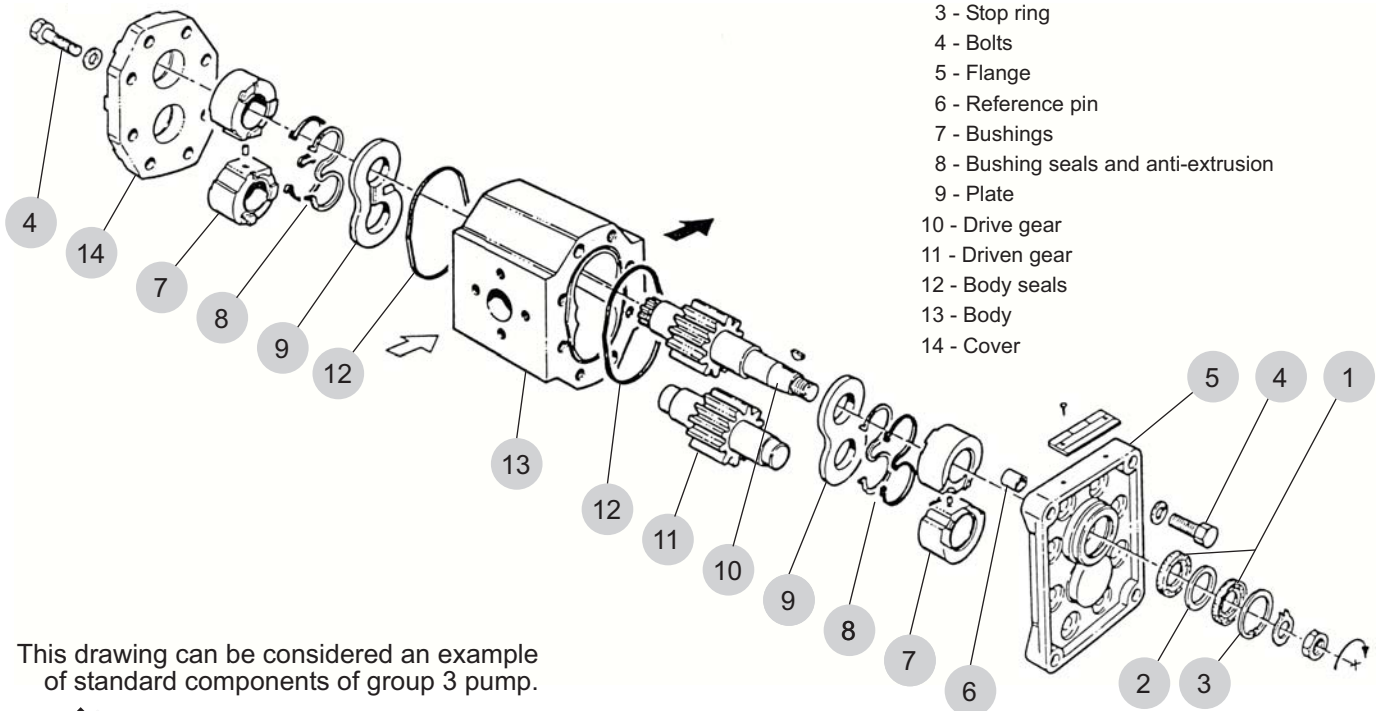





GEAR PUMP IN DETAIL

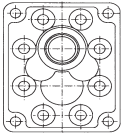
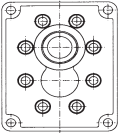
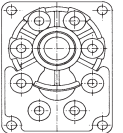
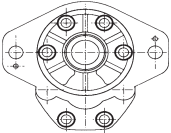

- 1 - Shaft seals
- 2 - Washer
- 3 - Stop ring
- 4 - Bolts
- 5 - Flange
- 6 - Reference pin
- 7 - Bushings
- 8 - Bushing seals and anti-extrusion
- 9 - Plate
- 10 - Drive gear
- 11 - Driven gear
- 12 - Body seals
- 13 - Body
- 14 - Cover

This drawing can be considered an example of standard components of group 3 pump.

COMBINATION WITH TYPES OF FLANGES AND DRIVES SHAFTS AVAILABLE

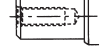
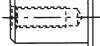
3PB	 P2	 P3	 B6	 S3	 Z1
 38-48	38 P1	48 P3			
 35			35 B6		
 05	05 P2		05 B6		
 55				55 S3	
 56				56 S3	
 66					66 Z1
 87				87 S3	
 88				88 S3	

Note: other versions available, please see shafts and flanges information.

3P/MB Group 3

GEAR PUMPS AND MOTORS "B" SERIES

Displacements up to 4.48 cu.in./rev
Pressure up to 4300 psi

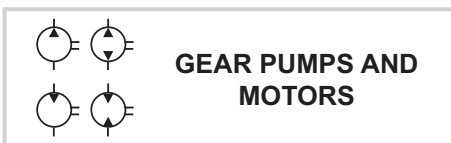

Displacements up to 73.4 cm³/rev
Pressure up to 300 bar

ASSEMBLING DIMENSIONS AND VALUES OF PRESSURE AND SPEED

Type		21*	27	33	38	46	55	65	75*	
Displacement	cm ³ /rev	20.6	27	33.5	38.7	46.9	54.1	63.1	73.4	
	cu.in./rev	1.26	1.65	2.04	2.36	2.86	3.30	3.85	4.48	
Dimension A	mm.	74	79	92	96	114	120	127	134	
	in.	2.91	3.11	3.62	3.78	4.49	4.72	5.00	5.27	
Dimension C	mm.	37	39.5	46	48	51	54	57.5	61	
	in.	1.46	1.56	1.81	1.89	2.01	2.13	2.26	2.40	
Working pressure	p1	bar	250			245	220	200	180	
		psi	3600			3500	3190	2900	2600	
Intermittent pressure	p2	bar	280			265	240	220	200	
		psi	4000			3840	3480	3140	2900	
Peak pressure	p3	bar	300			275	250	240	220	
		psi	4300			3950	3600	3450	3190	
Max. speed at	p2	rpm	3000			2750	2500			
Min. speed at	p1	rpm	600			500		400		
Weight		kg	5.1	5.3	5.8	6	7	7.3	8	8.4
		lbs	11.2	11.7	12.8	13.2	15.4	16.1	17.6	18.5

*Available for quantity, please contact our sales department.

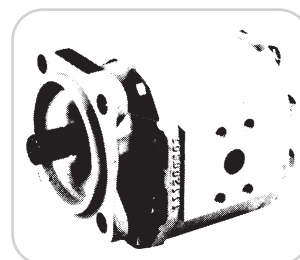
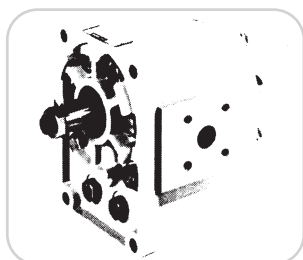
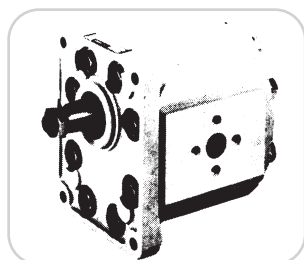
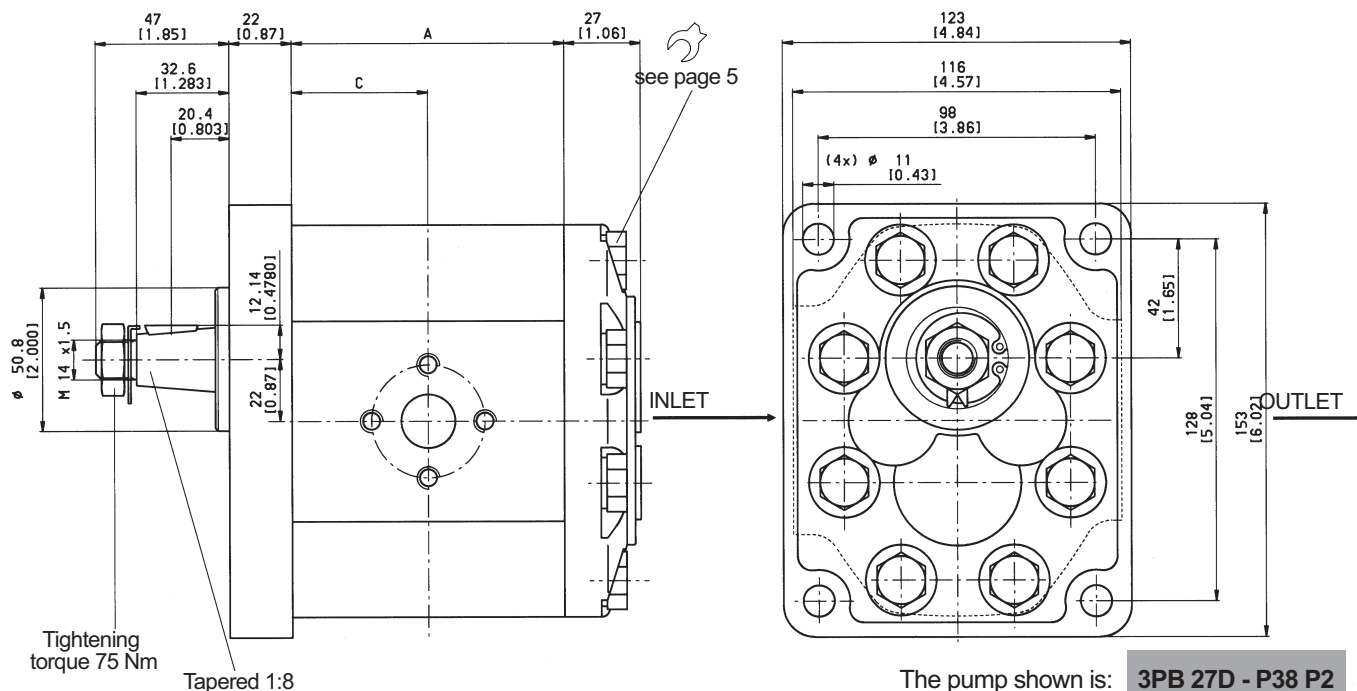

VERSION INTERCHANGEABLE WITH 3.5PC

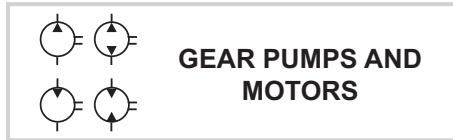

3P/MB VERSION INTERCHANGEABLE WITH 3.5PC MEANS THAT THE FLANGE HAS THE SAME DISTANCE BETWEEN CENTER HOLES OF 3.5PC

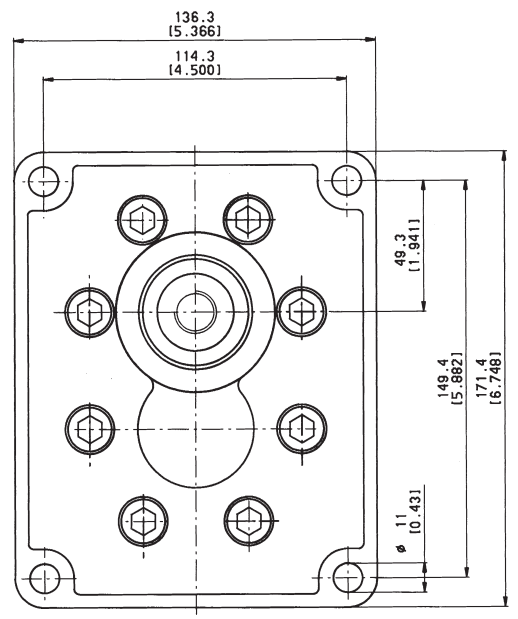
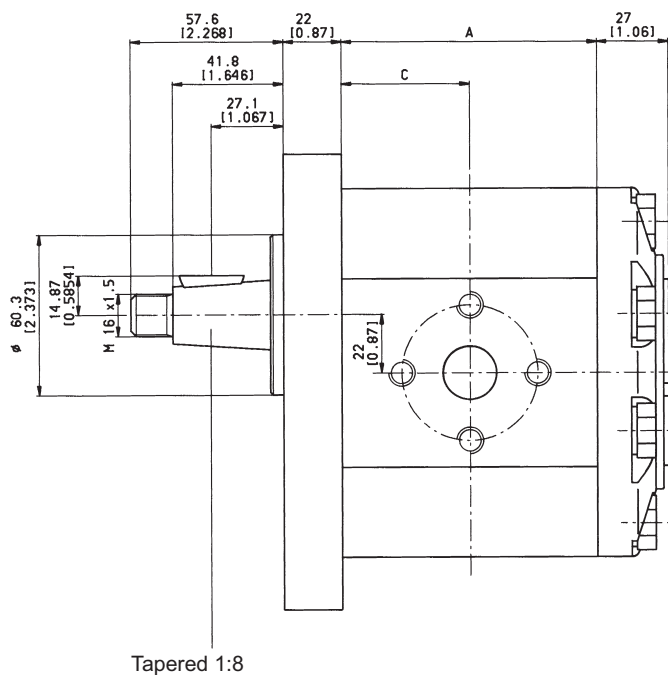

Example how to order: **3PB 46D - P48 P3**

Type		46	55	65	75	
Displacement	cm ³ /rev	46.9	54.1	63.1	73.4	
	cu.in./rev	2.86	3.30	3.85	4.48	
Dimension A	mm.	114	120	127	134	
	in.	4.49	4.72	5.00	5.27	
Dimension C	mm.	51	54	57.5	61	
	in.	2.01	2.13	2.26	2.40	
Working pressure	p1	bar	245	220	200	180
		psi	3500	3190	2900	2600
Intermittent pressure	p2	bar	265	240	220	200
		psi	3840	3480	3140	2900
Peak pressure	p3	bar	275	250	240	220
		psi	3950	3600	3450	3190
Max. speed at	p2	rpm	2750	2500		
Min. speed at	p1	rpm	500	400		
Weight		kg	7.5	7.8	8.2	8.65
		lbs	16.5	17.2	18.1	19.1

For unidirectional motor inlet/outlet ports are reversed.

FLANGED PORTS

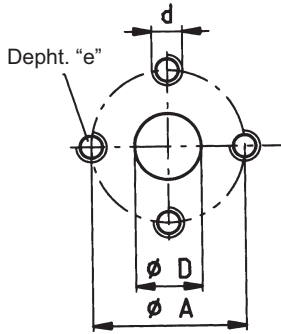

Type	INLET				OUTLET			
	ØD	ØA	d	e	ØD	ØA	d	e
21	22 (0.85")	51 (2.01")	M10	16 (0.62")	17.5 (0.68")	40 (1.56")	M8	13 (0.51")
From 27 to 55	27 (1.05")							

Standard version (for displacements 65 - 75 please contact our sales dept.)

46*	27 (1.05")	51 (2.01")	M10	16 (0.62")	20 (0.78")	51 (2.01")	M10	16 (0.62")
55*								
65*	33 (1.30")	62 (2.44")	M12	20 (0.78")				
75*								

*For version 48 P3 (version interchangeable with 3.5PC see page 11)

Tightening torque for different threads:
M8 : 22 Nm
M10: 50 Nm
M12: 90 Nm

code P

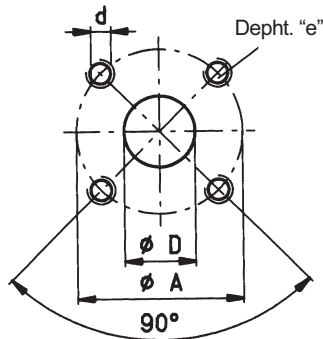

Type	INLET				OUTLET			
	ØD	ØA	d	e	ØD	ØA	d	e
21	22 (0.85")	55 (2.17")	M8	13 (0.51")	19 (0.74")	55 (2.17")	M8	13 (0.51")
From 27 to 55	27 (1.05")							

For displacements 65 - 75 please contact our sales dept.

Tightening torque for different threads:
M8 : 22 Nm
M10: 50 Nm
M12: 90 Nm

code B

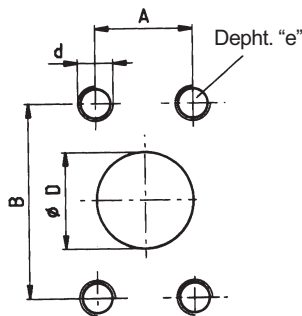

Type	INLET					OUTLET				
	ØD	A	B	d	e	ØD	A	B	d	e
From 21 to 38	26 (1.01")	26.2 (1.02")	52.4 (2.06")	M10	18 (0.70")	19 (0.74")	22.2 (0.86")	47.6 (1.87")	M10	18 (0.70")
From 46 to 65	32 (1.26")	30.2 (1.19")	58.7 (2.31")			26 (1.01")	26.2 (1.02")	52.4 (2.06")		

Tightening torque for different threads:
M8 : 22 Nm
M10: 50 Nm
M12: 90 Nm

code W

Available for quantity, please get in touch with our sales dept.

GEAR PUMPS AND MOTORS "B" SERIES

3P/MB Group 3

For unidirectional motor inlet/outlet ports are reversed.

Type	INLET					OUTLET				
	ØD	A	B	d	e	ØD	A	B	d	e
From 21 to 38	26 (1.01")	26.2 (1.02")	52.4 (2.06")	3/8-16 UNC	18 (0.70")	19 (0.74")	22.2 (0.86")	47.6 (1.87")	3/8-16 UNC	18 (0.70")
From 46 to 75	32 (1.26")	30.2 (1.19")	58.7 (2.31")	7/16-14 UNC		26 (1.01")	26.2 (1.02")	52.4 (2.06")		

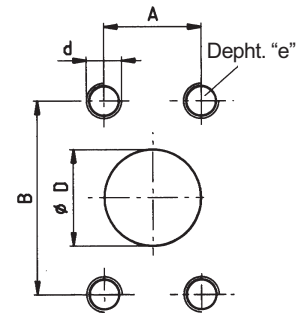

Tightening torque for different threads:
 M8 : 22 Nm
 M10: 50 Nm
 M12: 90 Nm

code S

Available for quantity, please get in touch with our sales dept.

THREADED PORTS

Type	INLET			OUTLET		
	A	B	ØC	A	B	ØC
From 21 to 38	G1"	22 (0.85")	27 (1.05")	G1"	22 (0.85")	27 (1.05")
From 46 to 75	G1 1/4"	24 (0.93")				

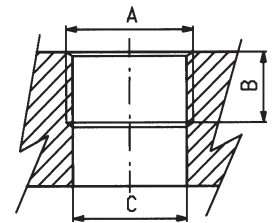

For displacements 65 - 75 please contact our sales dept.

British standard pipe parallel (BSPP)

code G

Type	INLET					OUTLET				
	A	B	ØC	Y	K	A	B	ØC	Y	K
From 21 to 38	1-5/16 12 UN (SAE 16)	19 (0.74")	21 (0.83")	49 (1.93")	3.3 (0.13")	1-1/16 12 UN (SAE 12)	19 (0.74")	15 (0.58")	41 (1.61")	3.3 (0.13")
From 46 to 75	1-5/8 12 UN (SAE 20)		27 (1.05")	24 (2.28")		1-5/16 12 UN (SAE 16)		21 (0.83")	49 (1.93")	

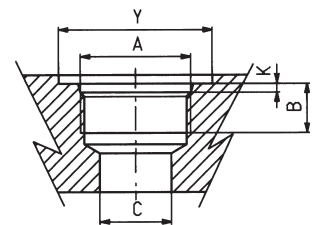

For displacements 65 - 75 please contact our sales dept.

SAE threaded (ODT)

code R

DRIVE SHAFTS

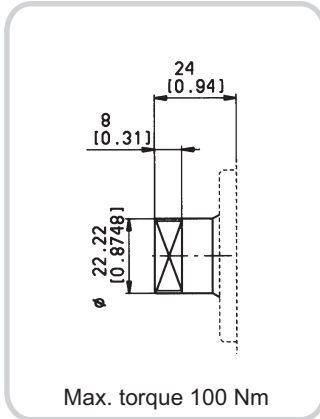

code 05

Tang drive for electric motors

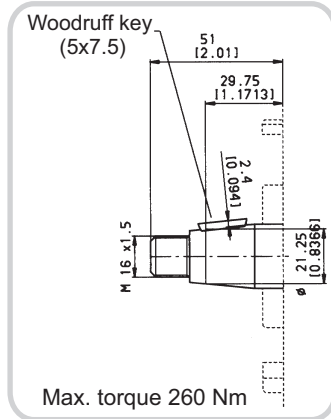

code 35

Tapered 1:5

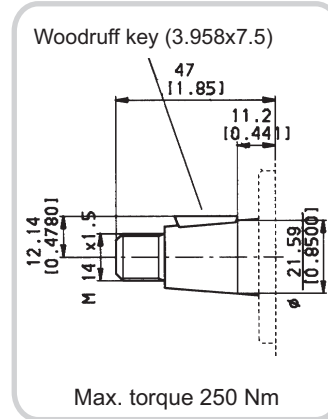

code 38

Tapered 1:8

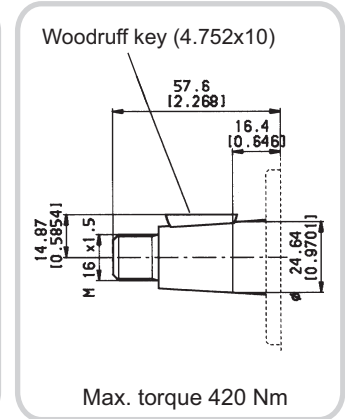

code 48

Tapered 1:8
for Types 46 - 55 - 65 - 75
interchangeable with 3.5pC

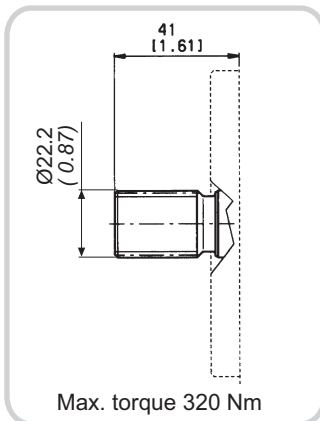

code 55

SAE B 13T-16/32DP
Ansi B92 1a 1976

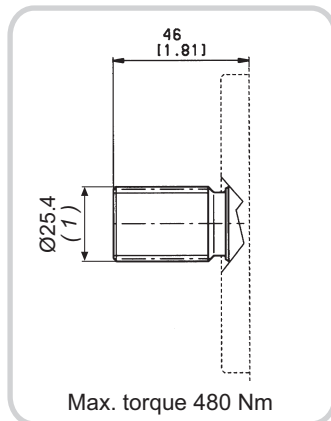

code 56

SAE BB 15T-16/32DP
Ansi B92 1a 1976

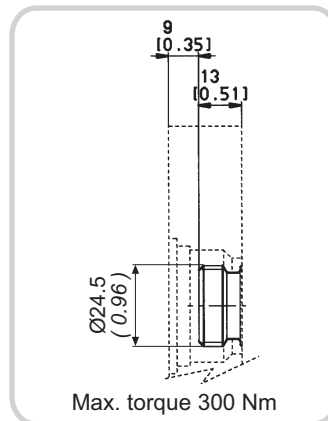

code 63

DIN 5482 splined

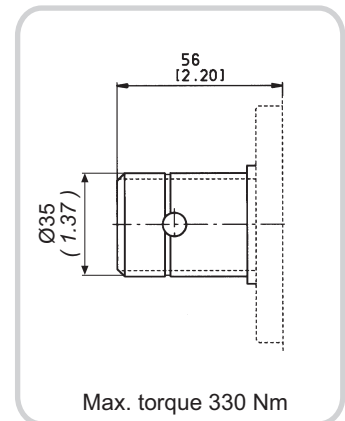

code 66

B8x32x36
DIN 5462-6g7

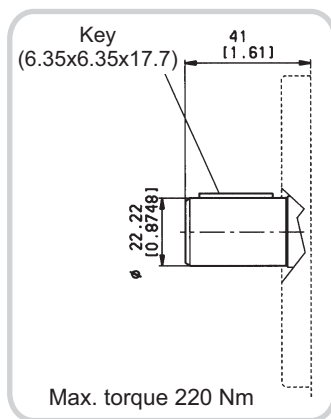

code 87

SAE B parallel

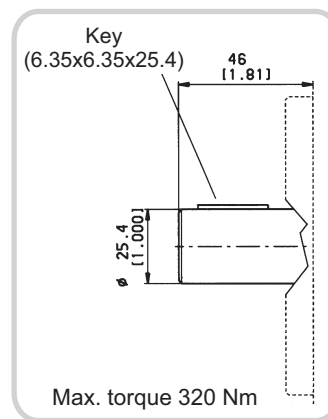

code 88

SAE BB parallel

MOUNTING FLANGES

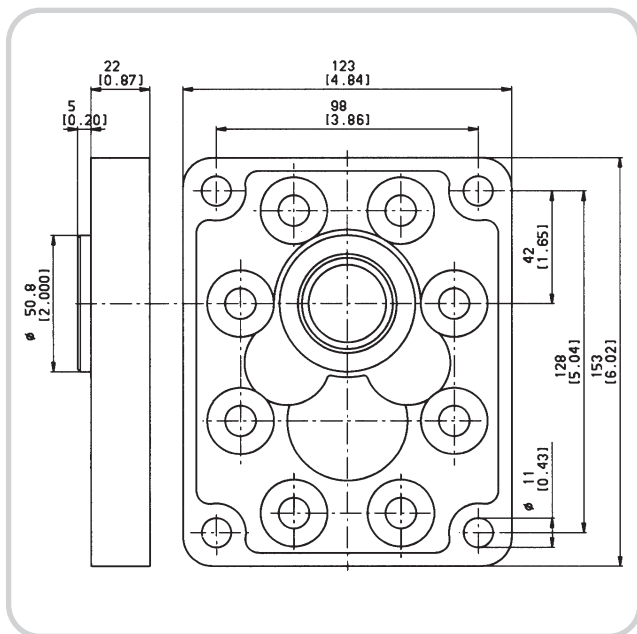

code P2 With shafts code 05 - 38

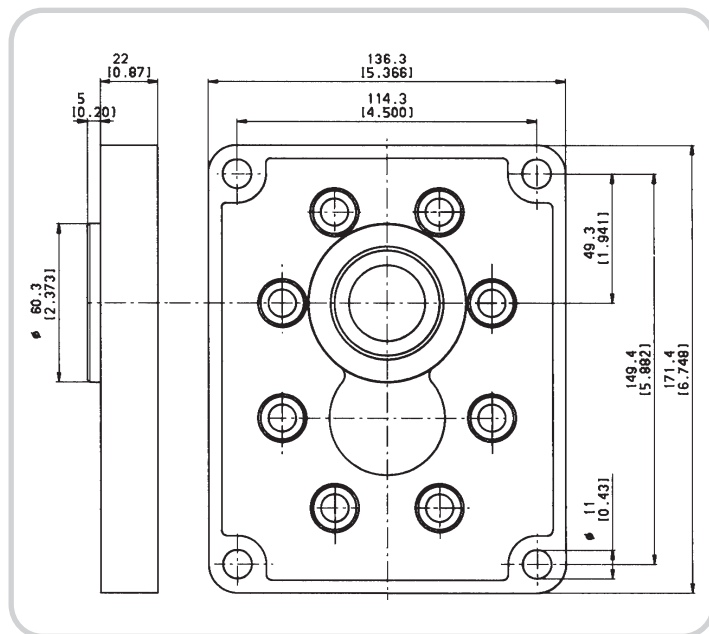

code P3 With shaft code 48

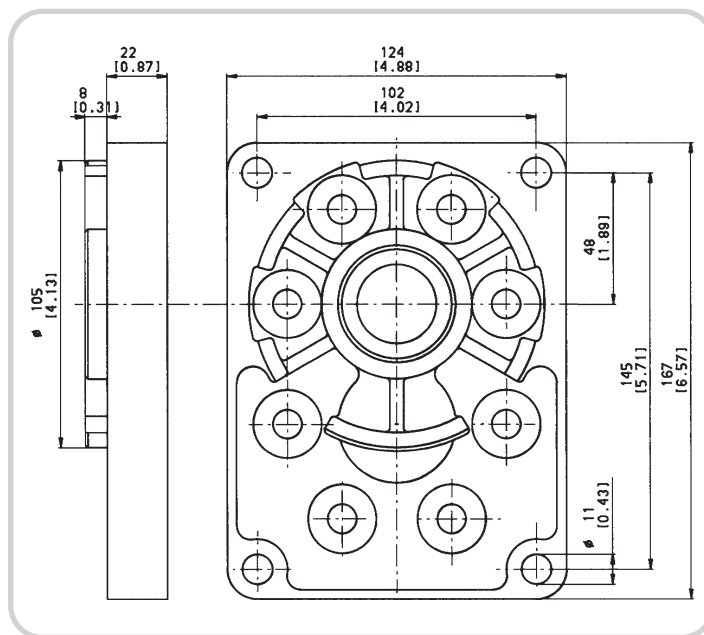

code B6 With shafts code 05 - 35

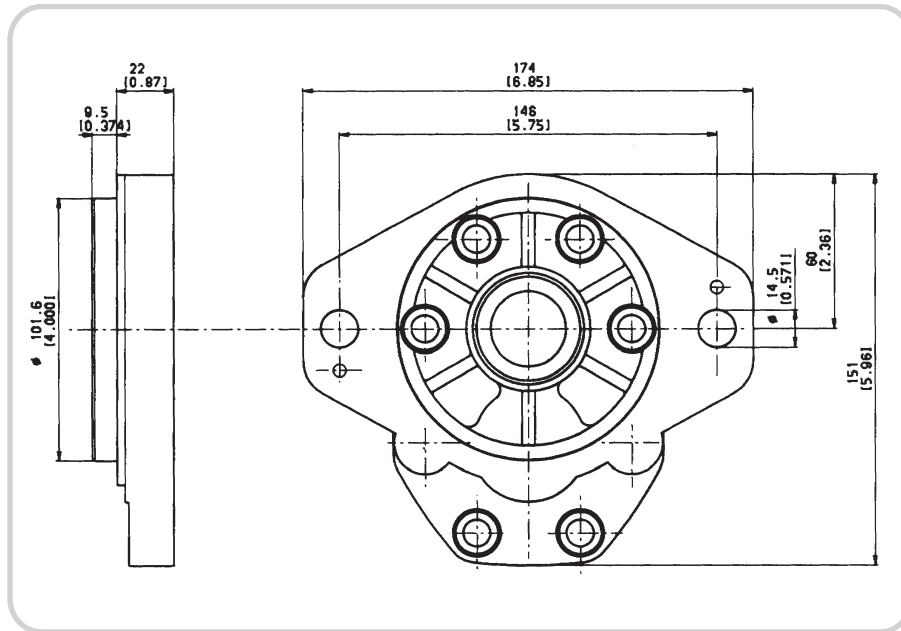

code S3 With shafts code 55-56-87-88
SAE B mounting flange

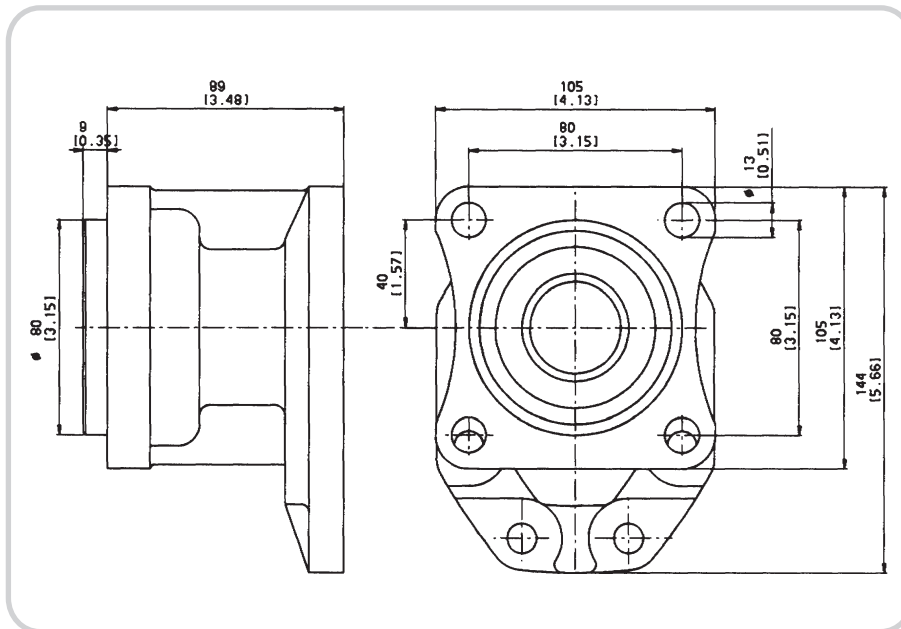

code Z1 With shaft code 66
Flange on gear box ZF

OUTRIGGER BEARING

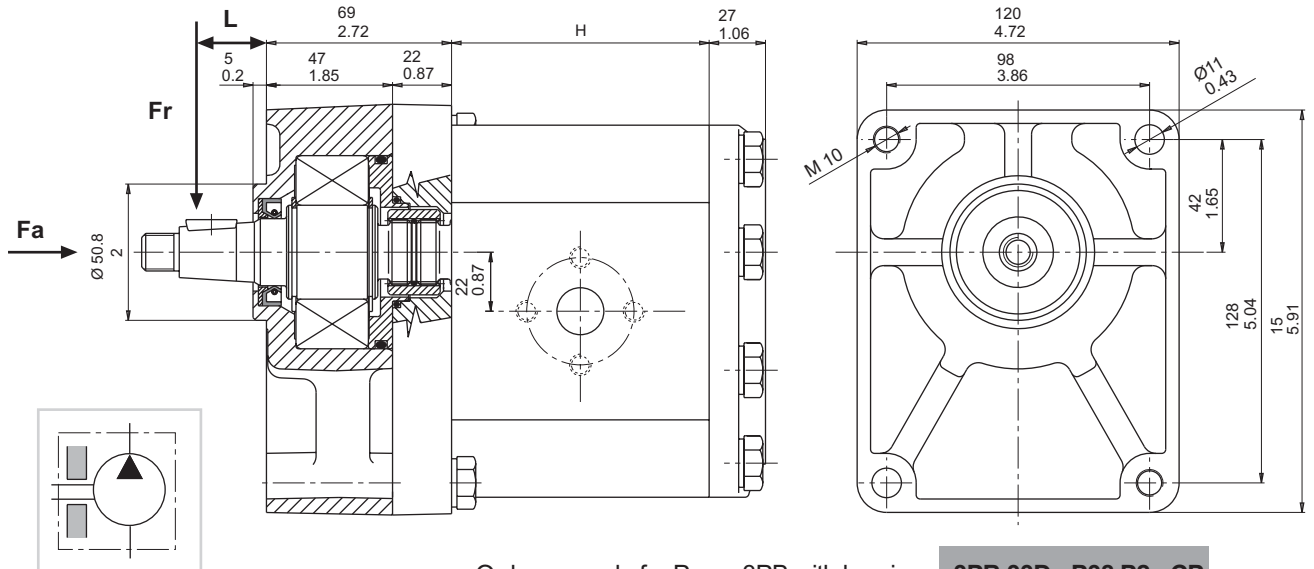

Order example for Pump 3PB with bearing: **3PB 33D - P38 P2 - CP**

Type	H (mm/inch)
21	74 (2.91")
27	79 (3.11")
33	92 (3.62")
38	96 (3.78")
46	114 (4.49")
55	120 (4.72")
65	127 (5.00")

The diagram shows the maximum radial load referring to a bearing life of 3000 hours.

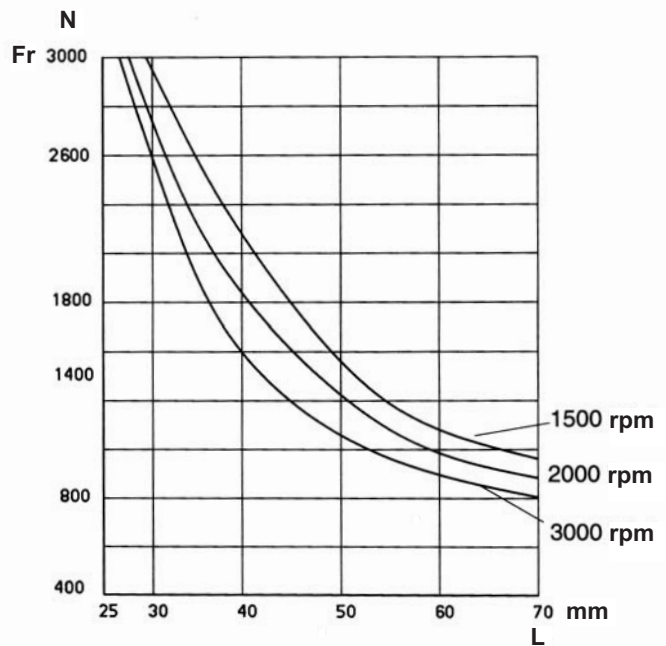
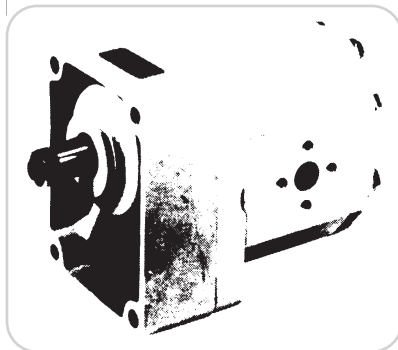

To calculate the absorbed pump-torque or motor efficiency, please use the following formula:

$$C(Nm) = \frac{C_y \Delta p}{62.8}$$

C_y = Displacement pump

Δp = Pressure (bar/psi)

REAR COVERS

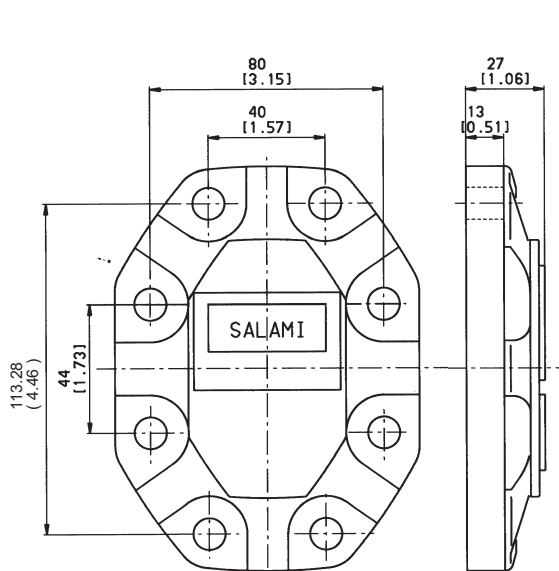

Standard rear cover for unidirectional pumps and motors.

C
G 3/8
3/4"-16 UNF(SAE 8)

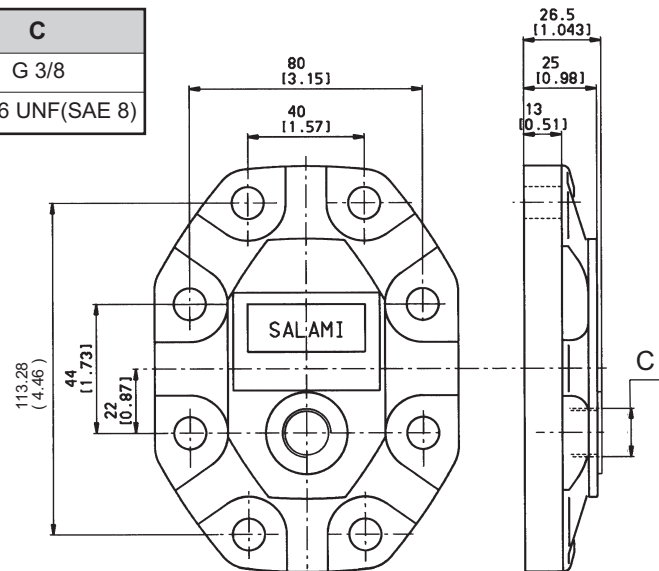

Standard rear cover for reversible pumps and motors with external drain port ΦC .

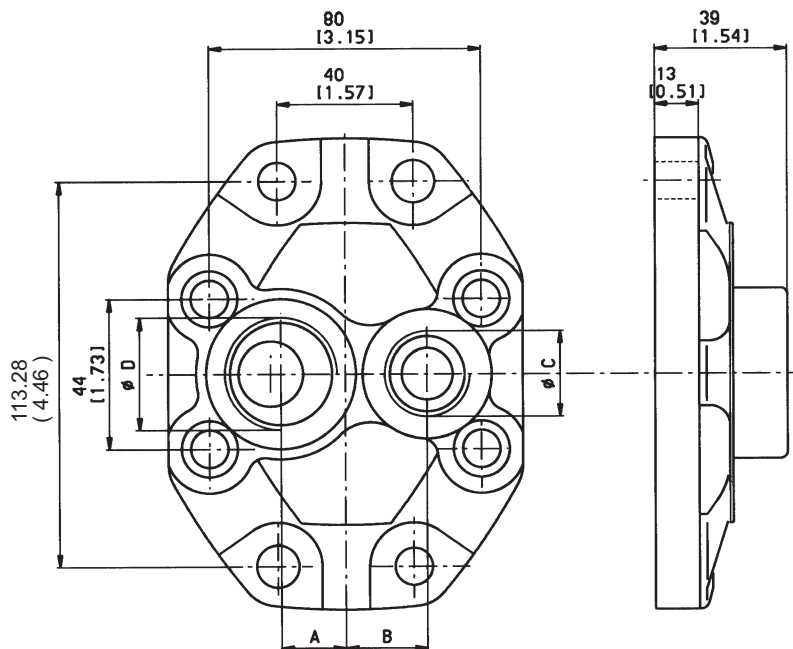

code 1

For pumps with threaded rear ports, suitable up to 80 l/min delivery.

In case of order please specify the type of ports:

D	C	A	B
G1"	G 3/4	19 (0.74")	24 (0.93")
1"-5/16-12 UN(SAE 16)	1"-1/16-12 UN(SAE 12)	20 (0.78")	25 (0.97")

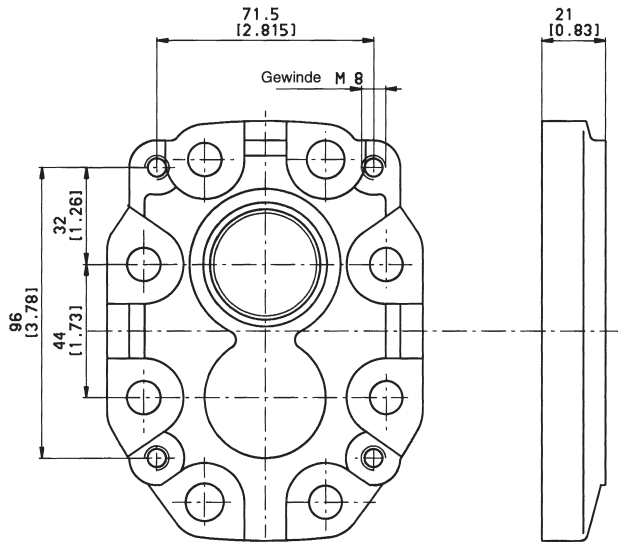

code PD2

Rear cover for 3PB/2PB

Order example:

3PB 46D - P38 P2 - PD2

REAR COVER WITH PRIORITY VALVE

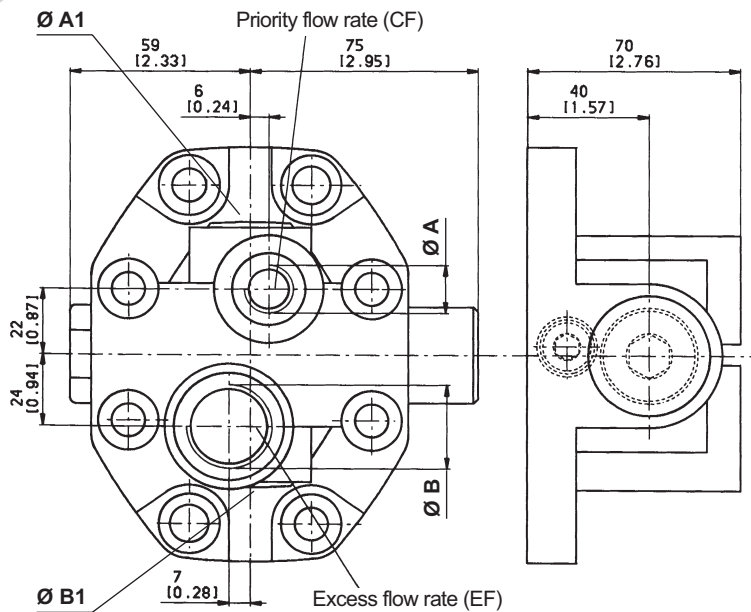

code VP

Priority flow valve,
excess flow
to second actuator.

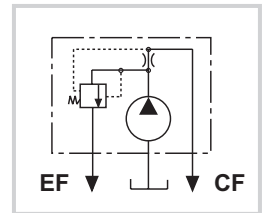

code VPS

Priority flow valve,
excess flow
to second actuator
with pressure relief
valve on priority
flow line.

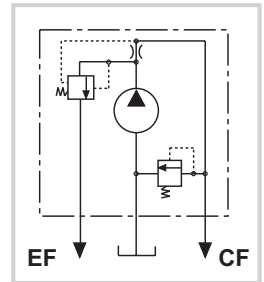

CALIBRATED ORIFICE Ø d(mm/inch)	FLOW RATE (l/min - gpm) ± 10%
2.5 (0.10")	6 (1.5)
2.9 (0.11")	8 (2.1)
3.2 (0.13")	10 (2.6)
3.6 (0.14")	12 (3.1)
3.9 (0.15")	14 (3.6)
4.4 (0.17")	18 (4.7)
4.6 (0.18")	20 (5.2)
5.2 (0.20")	25 (6.6)
5.8 (0.23")	32 (8.4)
6.4 (0.25")	40 (10.5)

PRIORITY FLOW DIVIDERS (VP - VPS)

3 way flow control valve housed in a special cast iron which ensures two flows can be loaded at the same time for supplying two separate circuits defined priority flow(CF) remains constant regardless of pump speed and system pressure variations. The second defined excess flow(EF) is directly proportional to pump speed. Priority flow is determined by diameter of hole on threaded dowel (see table). The max. pressure of the priority circuit can be limited by valve which relieves into pump suction.

Ø B (Ø B1)	Ø A (Ø A1)
G 3/4	G 3/8
1"-1/16-12 UN(SAE 12)	9/16-18 UNF(SAE 6)

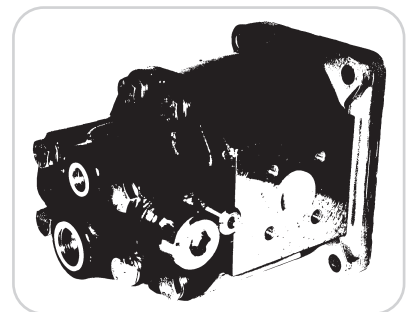

ASSEMBLING DIMENSIONS



Type		21	27	33	38	46	55	65	75
Dimension A (flanges B2 - B3)	mm in					22 0.87			
Dimension A (flanges Z1)	mm in					88 3.46			
Dimension B	mm in	37 1.44	39.5 1.54	46 1.79	48 1.87	51 2.00	54 2.12	57.5 2.24	61 2.40
Dimension H	mm in	74 2.91	79 3.11	92 3.62	96 3.78	114 4.49	120 4.72	127 5.00	134 5.27

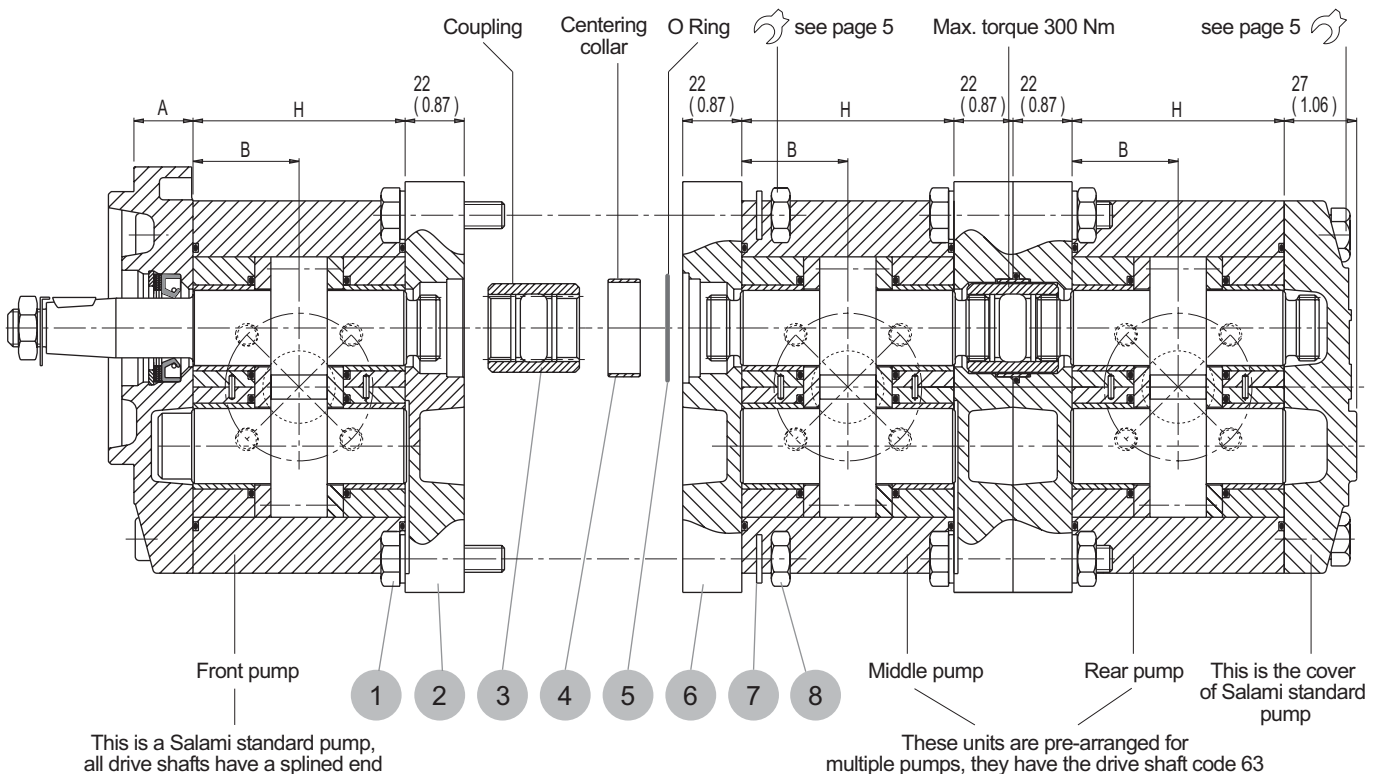

1 2 3 4 5 6 7 8 = kit multiple pumps

The **3PB** pumps can be easily transformed into front pump in the multiple units. All drive shafts are pre-arranged and have a splined end according DIN 5482. The first unit must always be the same size or bigger than following units. The features and performances are the same of the corresponding single units: only in the case of simultaneous operating you have to verify that the inlet torque is lower than the max. transmissible by the drive shaft.

Example to order: **3PB 56/38/21D - B38 S3**

3PB COMBINATION WITH 2PE PUMP (COMMUNICATING INLET PORTS)

For dimensions rear pump see catalogue:
GEAR PUMPS GROUP 2
3PB combination with 2PE (communicating inlet ports) components kit:

1 2 3

Order example:
3PB 46/2PE 13.8D - P38 P2

Release with common suction on the first bigger pump available. Please consult our sales dept.

For dimensions (A B H) see corresponding multiple pumps page 20

3PB COMBINATION WITH 2PE PUMP WITH SEPARATED STAGES

For dimensions and features rear pump see catalogue:
GEAR PUMPS GROUP 2

3PB combination with 2PE (separated stages) components kit:

1 2 3 4 5

As you can see in the 2PE, drive shaft and assembling screws are longer than standard 2PE.

code AS

Order example:
3PB 46/2PE 13.8D - P38 P2 - AS

For dimensions (A B H) see corresponding multiple pumps page 20

3P/MB Group 3

A=250 bar (3600 psi)
 B=200 bar (2900 psi)
 C=150 bar (2175 psi)
 D=100 bar (1450 psi)
 E=50 bar (725 psi)

Performance curves carried out with oil viscosity at 16 cSt and oil temperature at 60°C

PUMP PERFORMANCE CURVES

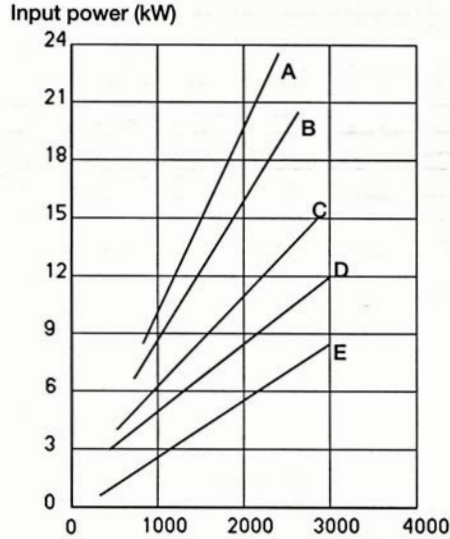

3PB 21

Shaft speed
r.p.m.

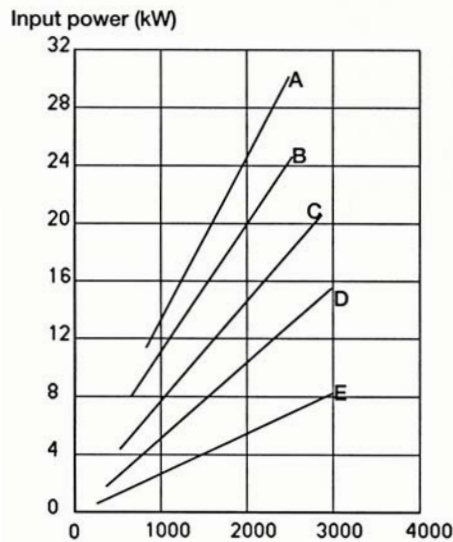
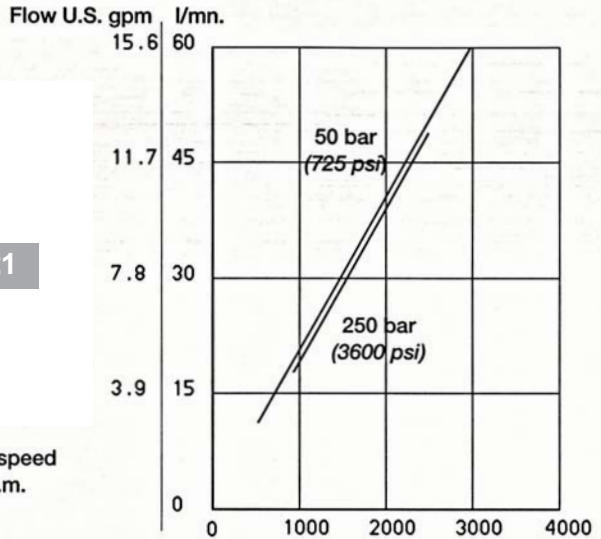

3PB 27

Shaft speed
r.p.m.

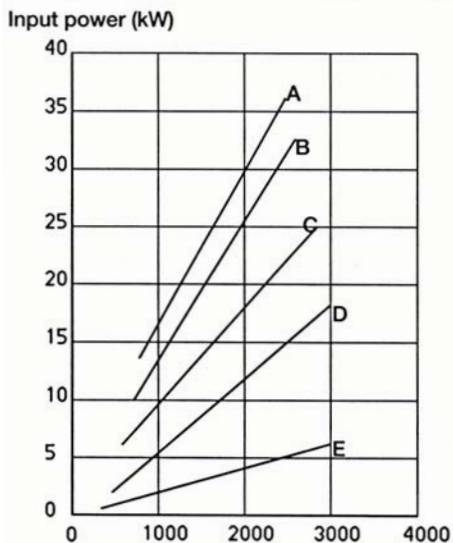
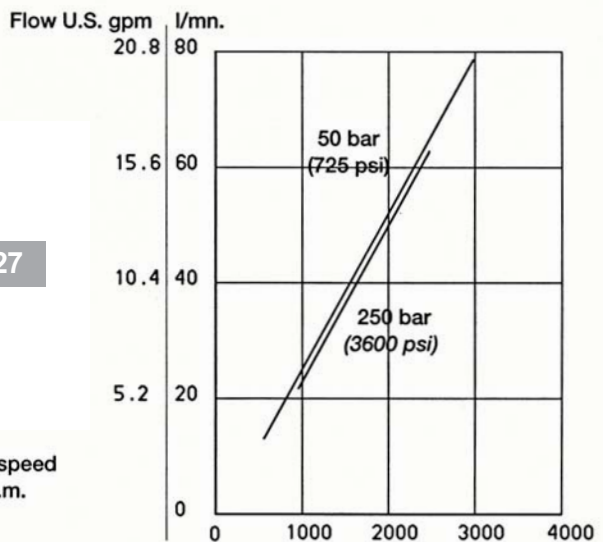

3PB 33

Shaft speed
r.p.m.

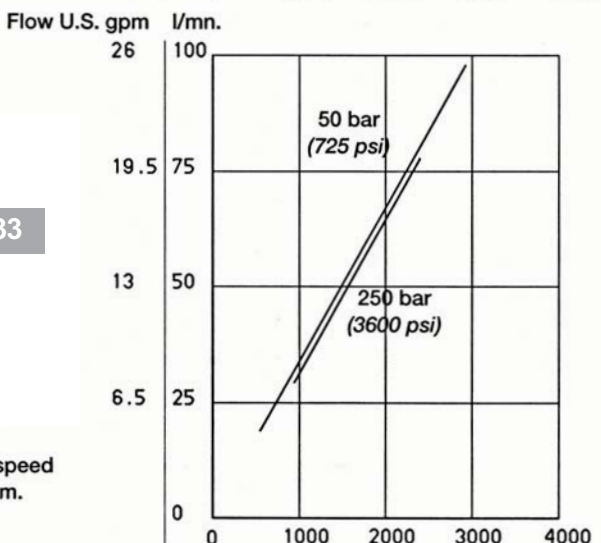

A=250 bar (3600 psi)
 B=200 bar (2900 psi)
 C=150 bar (2175 psi)
 D=100 bar (1450 psi)
 E=50 bar (725 psi)

3P/MB Group 3

Performance curves carried out with oil viscosity at 16 cSt and oil temperature at 60°C

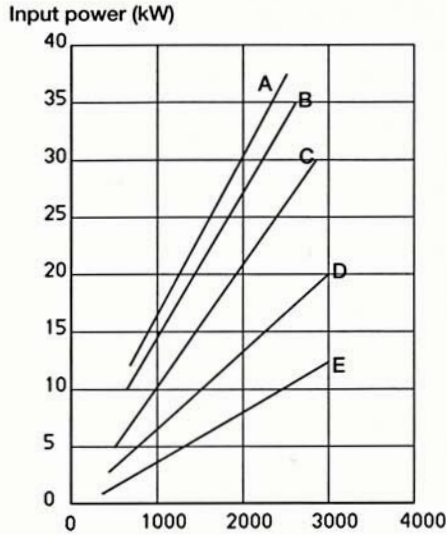

3PB 38

Shaft speed
r.p.m.

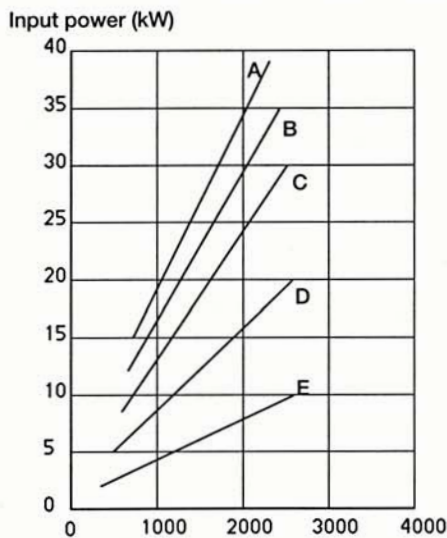
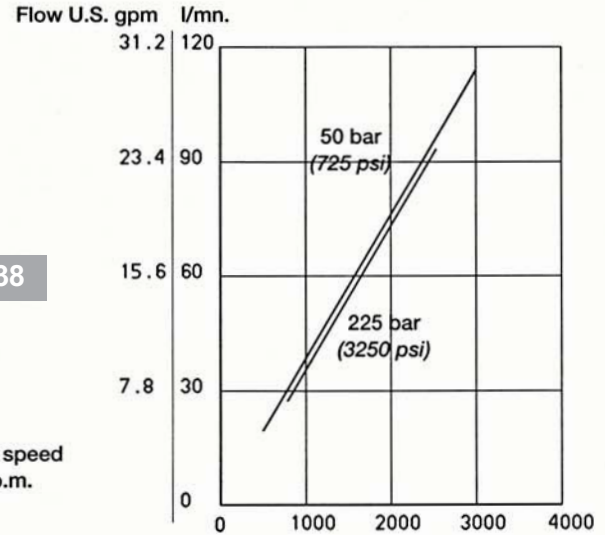

3PB 46

Shaft speed
r.p.m.

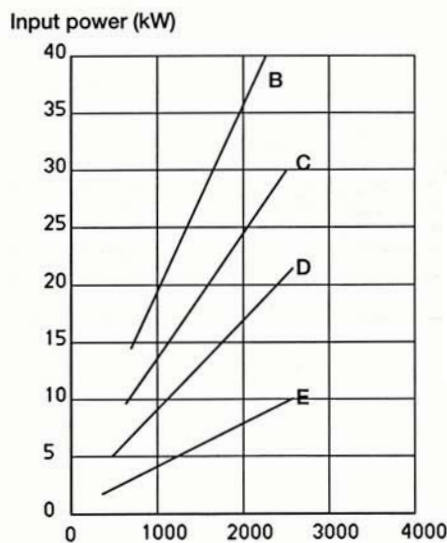
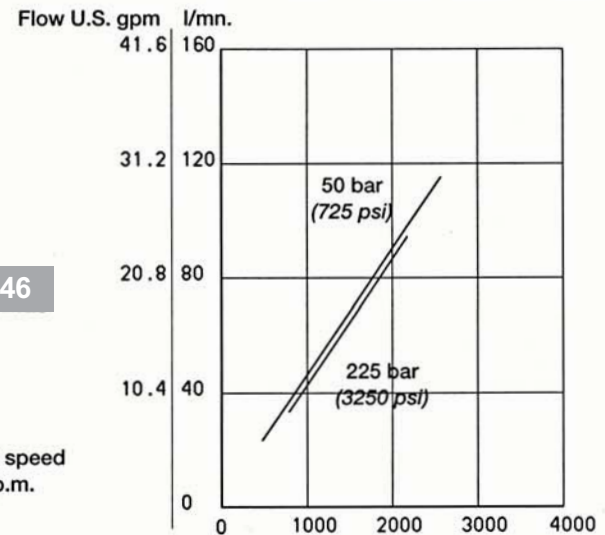

3PB 55

Shaft speed
r.p.m.

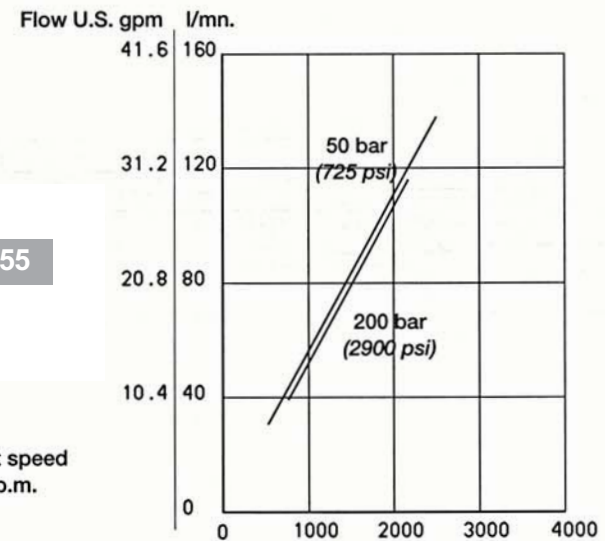

3P/MB Group 3

A=250 bar (3600 psi)
 B=200 bar (2900 psi)
 C=150 bar (2175 psi)
 D=100 bar (1450 psi)
 E=50 bar (725 psi)

Performance curves carried out with oil viscosity at 16 cSt and oil temperature at 60°C

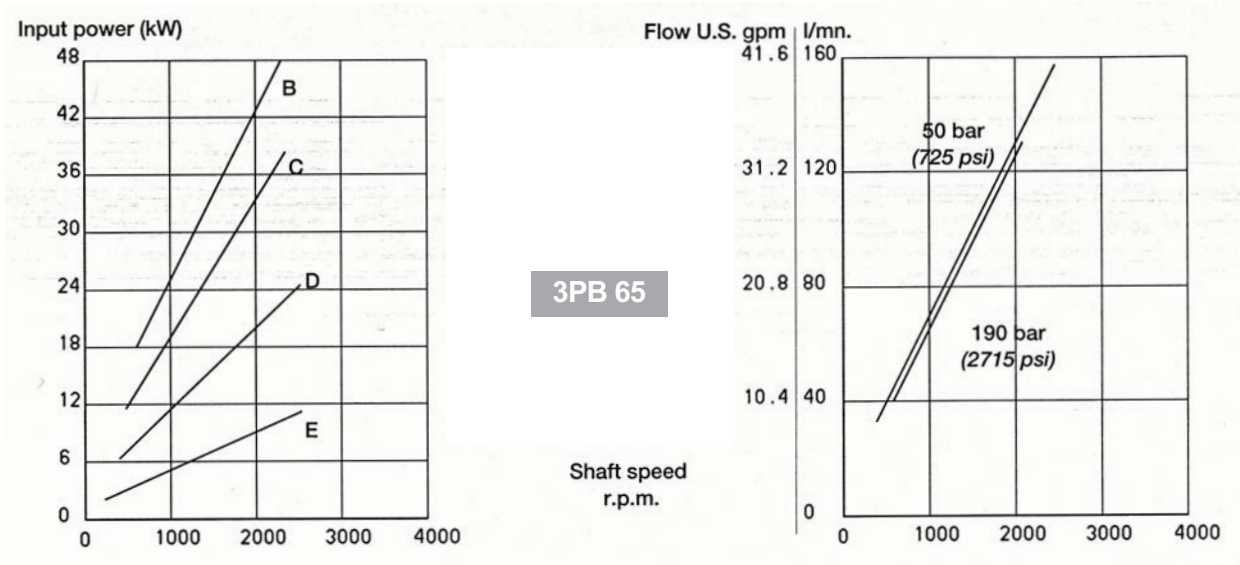

Torque _____
 Output _____

A=210 bar (3000 psi) D=105 bar (1500 psi)
 B=175 bar (2530 psi) E=70 bar (1000 psi)
 C=140 bar (2000 psi) F=35 bar (500 psi)

3P/MB Group 3

Performance curves carried out with oil viscosity at 16 cSt and oil temperature at 60°C

MOTOR PERFORMANCE CURVES

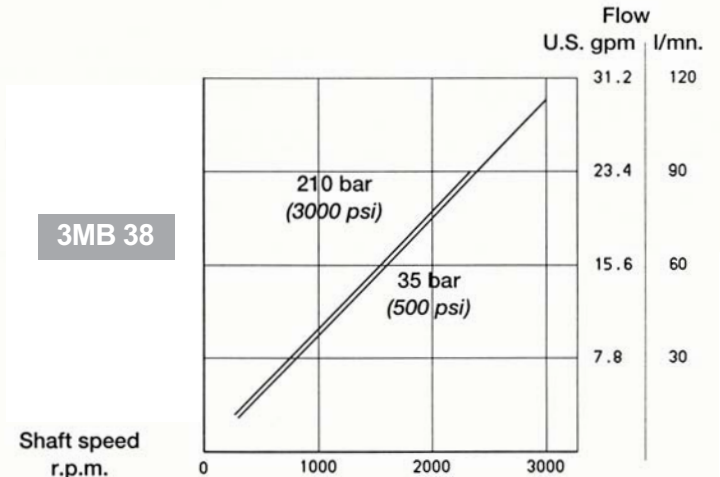
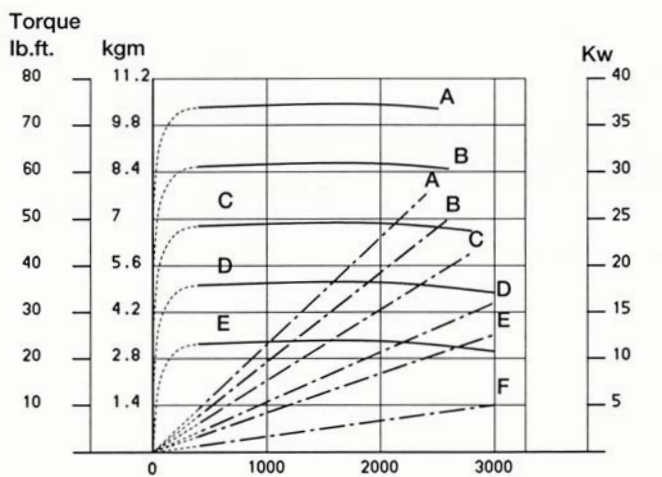
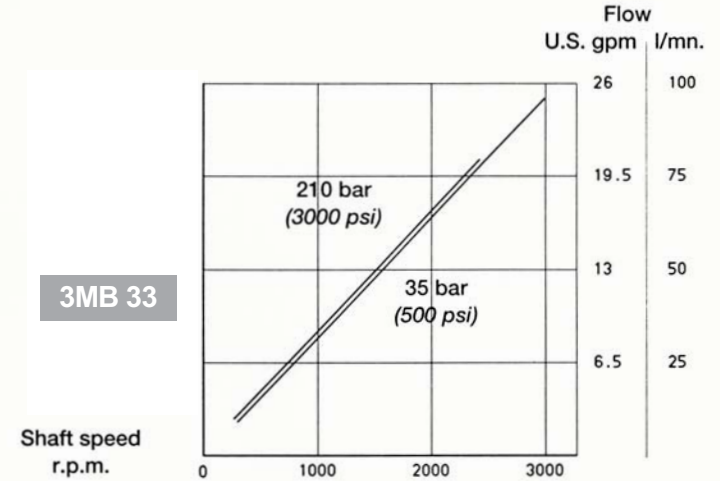
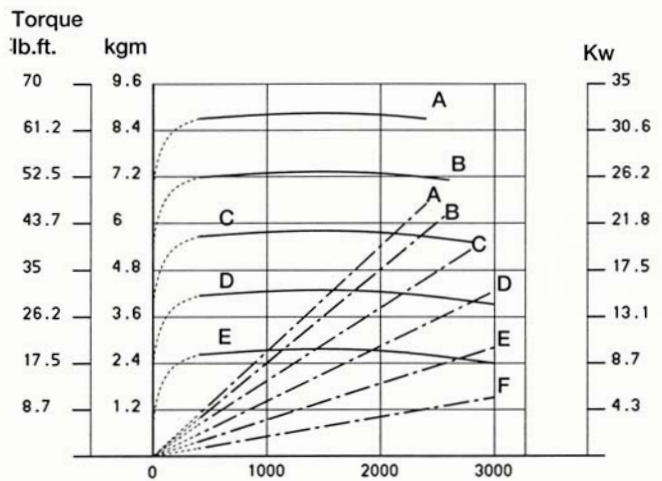
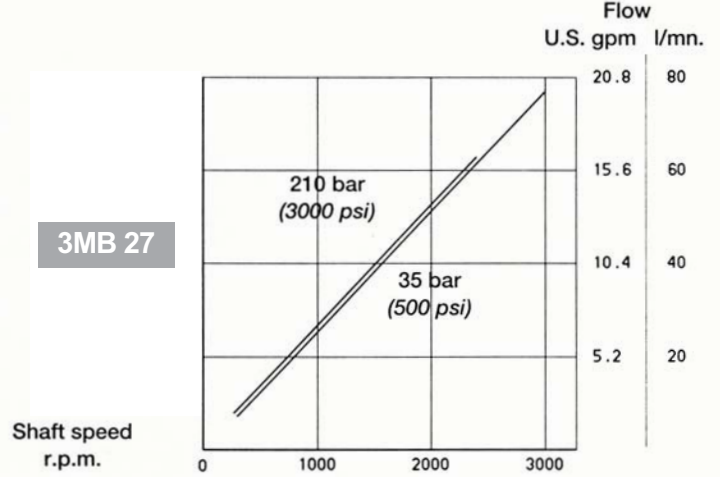
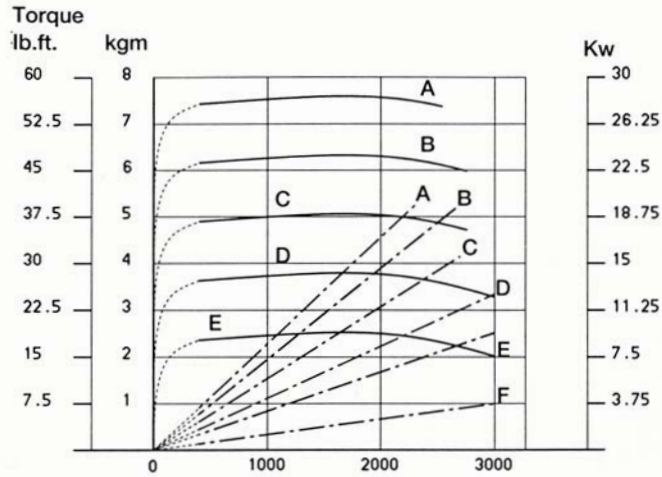

3P/MB Group 3

Torque _____
Output - - - - -

A=210 bar (3000 psi) D=105 bar (1500 psi)
B=175 bar (2530 psi) E=70 bar (1000 psi)
C=140 bar (2000 psi) F=35 bar (500 psi)

Performance curves carried out with oil viscosity at 16 cSt and oil temperature at 60°C

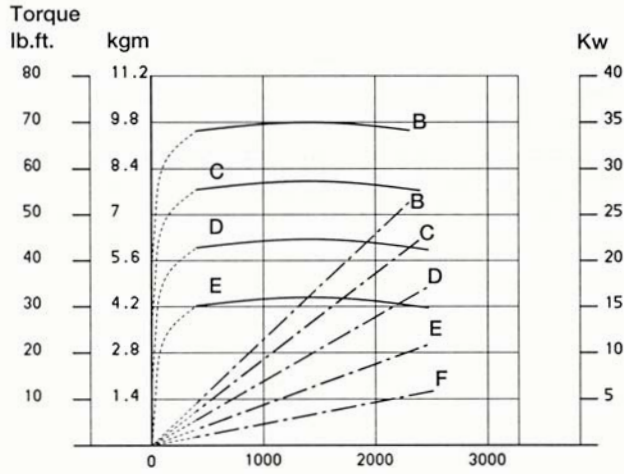

3MB 46

Shaft speed
r.p.m.

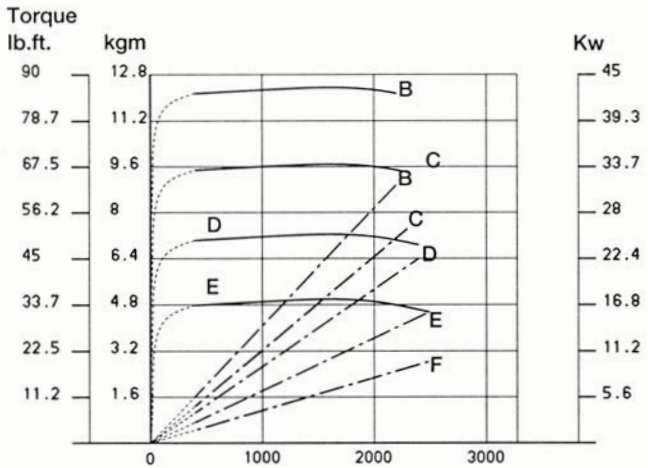
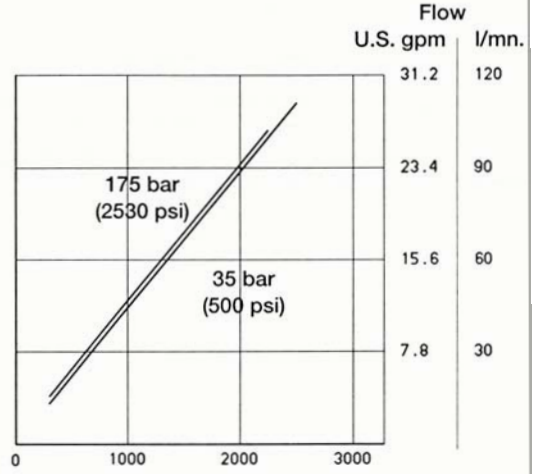

3MB 55

Shaft speed
r.p.m.

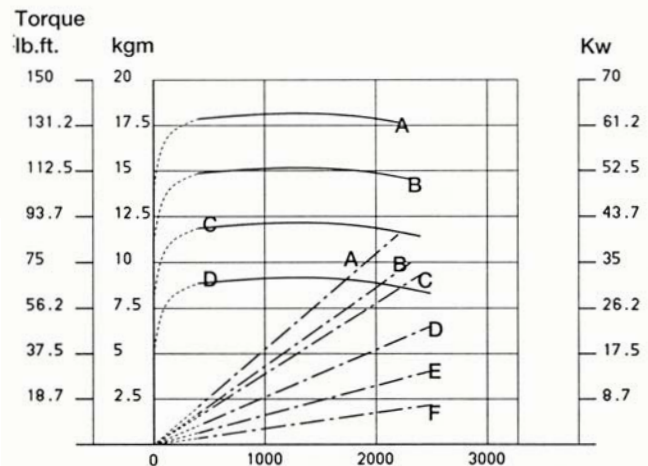
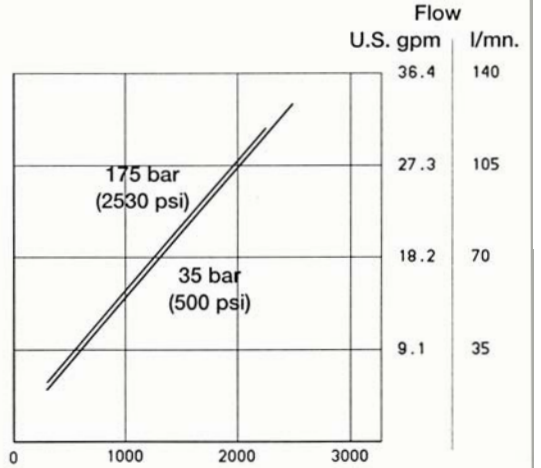

3MB 65

Shaft speed
r.p.m.

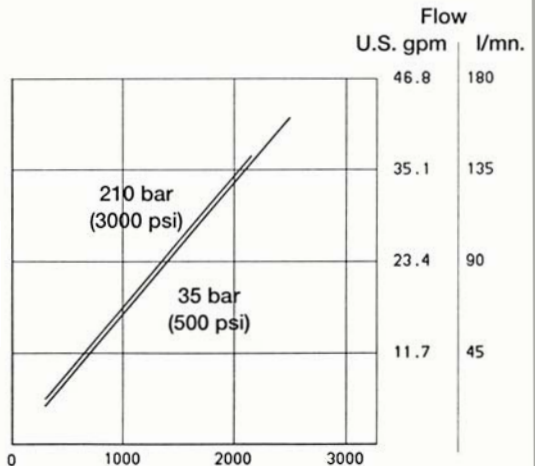

PORT CONNECTORS

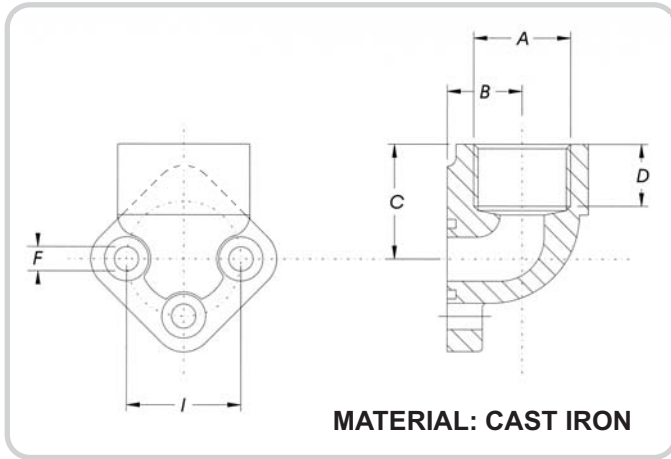

Type G

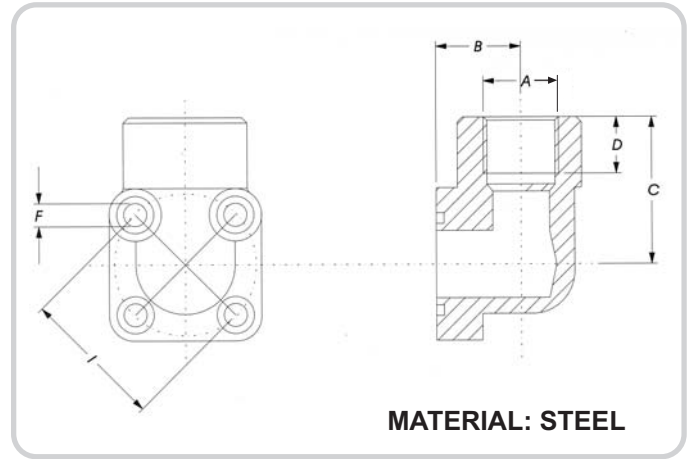

Type GB

AVAILABLE CONNECTORS - DIMENSIONS AND CODE

Type	C	B	I	D	Ø F	Ø A	ORDERING CODE COMPLETE OF SCREW - SPRING WASHER - O RING
2 G	36	21	40	16	8.5	G 3/4	4352 7011 0
3 G	43	27	51	21	10.5	G 1	4352 7013 0
4 G	55	34.5	62	27	12.5	G 1 1/4	4352 7017 0
3 GB/1	49	34	55	19	8.5	G 3/4	4352 7014 1
3 GB/2	49	34	55	19	8.5	G 1	4352 7015 1

SINGLE PUMPS/MOTORS

3 P B 33 D - P 38 P2 - V 1 - CP - PD2 - VP

DIMENSION

FUNCTION	CODE
Pump	P
Motor	M

SERIES

TYPE	DISPLACEMENTS	
21*	20.6 cm ³ /rev.	1.26 cu.in/rev.
27	27 cm ³ /rev.	1.65 cu.in/rev.
33	33.5 cm ³ /rev.	2.04 cu.in/rev.
38	38.7 cm ³ /rev.	2.36 cu.in/rev.
46	46.9 cm ³ /rev.	2.86 cu.in/rev.
55	54.1 cm ³ /rev.	3.30 cu.in/rev.
65	63.1 cm ³ /rev.	3.85 cu.in/rev.
75*	73.4 cm ³ /rev.	4.48 cu.in/rev.

ROTATION	CODES
Clockwise	D
Anti-clockwise	S
Reversible	R

PORTS (pag. 12 - 13)	CODES
Flanged ports european standard	P
Flanged ports german standard	B
GAS threaded ports (BSPP)	G
SAE threaded ports (ODT)	R
SAE flanged ports (UNC)	S*
SAE flanged ports (METRIC)	W*

DRIVE SHAFTS (pag. 14)	CODES
Tang drive for electric motors	05
Tapered 1:5	35
Tapered 1:8	38
Tapered 1:8 interchangeable with 3.5PC	48 (pag.11)
SAE B splined 13 T	55
SAE BB splined 15 T	56
DIN 5482 splined	63
DIN 5462 splined	66
SAE B parallel shaft Ø 22.22	87
SAE BB parallel shaft Ø 25.4	88

Setting main relief valve (bar)

Adjusted flow l/min

PD2=pre-arranged for 2PE rear (pag.19)

VALVES IN THE COVER (pag. 19)	CODES
Priority flow divider with excess flow to 2 nd actuator(pag.20)	VP
Like VP with main relief valve(pag.20)	VPS

OUTRIGGER BEARINGS (pag. 17)	CODES
European standard	CP

PORTS POSITION	CODE
Lateral ports standard	
Rear ports (pag. 18)	1

SEAL	CODE
Buna Standard	
Viton	V

MOUNTING FLANGES (pag. 15 - 16)	CODES
European standard Ø 50.8	P2
European std. interchangeable with 3.5PC Ø 60.3	P3 (pag.11)
German standard Ø 105	B6
SAE B 2 bolts Ø 101.6	S3
4 bolts for ZF gear box Ø 80	Z1

*Available for quantity, please contact our sales department

Order example:

3PB standard pump: 3PB 33D - P38 P2

3PB pump with priority flow divider and main relief valve: 3pB 33D - P38 P2 - VPS25/175

MULTIPLE PUMPS

3PB 46 / 33 27 D - P 38 P2 - V AS - CP - PD2 - VPS 2PE...

TYPE	DISPLACEMENTS	
21*	20.6 cm ³ /rev.	1.26 cu.in/rev.
27	27 cm ³ /rev.	1.65 cu.in/rev.
33	33.5 cm ³ /rev.	2.04 cu.in/rev.
38	38.7 cm ³ /rev.	2.36 cu.in/rev.
46	46.9 cm ³ /rev.	2.86 cu.in/rev.
55	54.1 cm ³ /rev.	3.30 cu.in/rev.
65	63.1 cm ³ /rev.	3.85 cu.in/rev.
75*	73.4 cm ³ /rev.	4.48 cu.in/rev.

ROTATION	CODES
Clockwise	D
Anti-clockwise	S

PORTS (pag. 12 - 13)	CODES
Flanged ports european standard	P
Flanged ports german standard	B
GAS threaded ports (BSPP)	G
SAE threaded ports (ODT)	R
SAE flanged ports (UNC)	S*
SAE flanged ports (METRIC)	W*

DRIVE SHAFTS (pag. 14)	CODES
Tang drive for electric motors	05
Tapered 1:5	35
Tapered 1:8	38
Tapered 1:8 interchangeable with 3.5PC	48 (pag.11)
SAE B splined 13 T	55
SAE BB splined 15 T	56
DIN 5482 splined	63
DIN 5462 splined	66
SAE B parallel shaft Ø 22.22	87
SAE BB parallel shaft Ø 25.4	88

See catalogue
GEAR PUMPS AND MOTORS
GROUP 2

See page before single pump

PD2 = pre-arranged for 2PE rear (pag.19)

OUTRIGGER BEARINGS (pag. 17)	CODES
European standard	CP

SUCTION TYPES	CODES
3PB combination with 2PE pump separated tank (pag.21)	AS

SEAL	CODE
Buna Standard	
Viton	V

MOUNTING FLANGES (pag. 15 - 16)	CODES
European standard Ø 50.8	P2
European std. interchangeable with 3.5PC Ø 60.3	P3 (pag.11)
German standard Ø 105	B6
SAE B 2 bolts Ø 101.6	S3
4 bolts for ZF gear box Ø 80	Z1

*Available for quantity, please contact our sales department

Order example:

Tandem pump: 3PB 33/27D - P38 P2

3PB pump combination with 2PE with separated stages: 3PB 48/2PE 16S - R56 S3 - AS

Tandem pump with priority flow divider in the rear pump: 3PB 33/27D - R55 S3 - VP18

WARRANTY

- We warrant products sold by us to be free from defects in material and workmanship.
- Our sole obligation to buyer under this warranty is the repair or replacement, at our option, of any products or parts thereof which, under normal use and proper maintenance, have proven defective in material or workmanship, this warranty does not cover ordinary wear and tear, abuse, misuse, overloading, alteration.
- No claims under this warranty will be valid unless buyer notifies SALAMI in writing within a reasonable time of the buyer's discovery of such defects, but in no event later than twelve (12) months from date of shipment to buyer.
- Our obligation under this warranty shall not include any transportation charges or cost of installation, replacement, field repair, or other charges related to returning products to us; or any liability for direct, indirect or consequential damage or delay. If requested by us, products or parts for which a warranty claim is made are to be returned transportation prepaid to our factory. The risk of loss of any products or parts thereof returned to SALAMI will be on buyer.
- No employee or representative is authorized to change any warranty in any way or grant any other warranty unless such change is made in writing and signed by an officer of SALAMI.



SALAMI spa
via Emilia Ovest 1006
41100 Modena Italy
telefono 059 387411
telefax 059 387500
export@salami.it - www.salami.it



SALAMI ITALIA srl
strada Pelosa 183
S. Pietro in Trigogna VI Italy
telefono 0444 240080
telefax 0444 240204
salami.italia@salami.it



SALAMI ESPAÑA
Poligono Industrial Armenteres
C/Primer de Maig, 18, Nave 4
08980 San Feliu de Llobregat
Barcelona
telefono 93-6327288
telefax 93-6667826
salami1@terra.es



SALAMI FRANCE
22, rue Louis Saillant
69120 Vaulx en Velin
Lyon
telefono 04 78 80 99 41
telefax 04 78 80 36 69
e.pasian@wanadoo.fr



149 S0. Chenango St. Ext.,
GREEN, NY 13778
Tel.: 001-607-6565702
Fax.:001-607-6565704
info@salamihydraulics.com