

# Axial Piston Variable Pump A4VG

Series 32

**RE 92003-01-B/04.08**

Replaces:  
RE 92003-11-B/06.06  
RE 92003-21-B/05.06  
English

## Operating Instructions

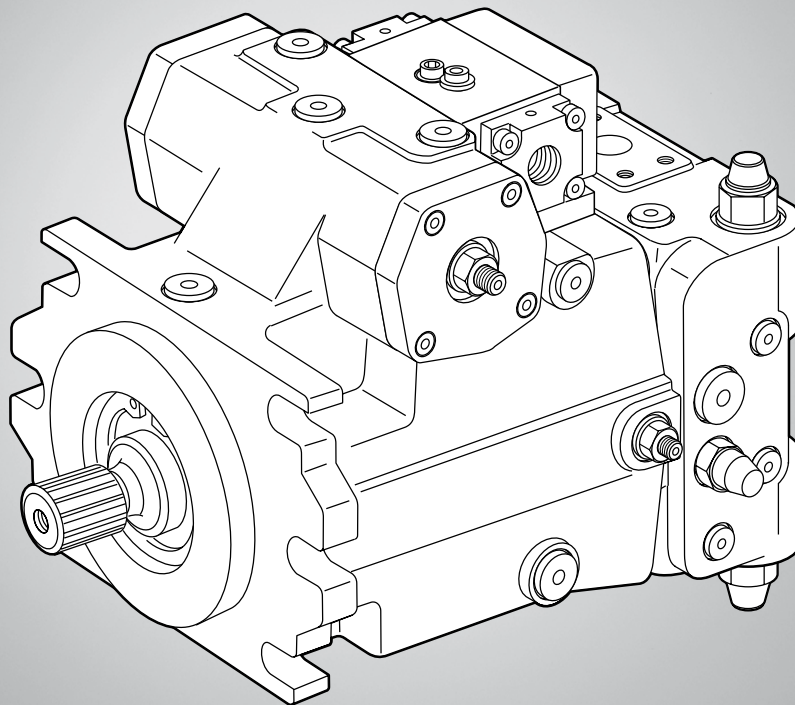

The data specified above only serve to describe the product. No statements concerning a certain condition or suitability for a certain application can be derived from our information. The information given does not release the user from the obligation of own judgment and verification. It must be remembered that our products are subject to a natural process of wear and aging.

© This document, as well as the data, specifications and other information set forth in it, are the exclusive property of Bosch Rexroth AG. It may not be reproduced or given to third parties without its consent.

An example configuration is shown on the title page. The delivered product may, therefore, differ from the product which is pictured.

The original operating instructions were created in the German language.

# Contents

<b>1</b>	<b>About this document</b> .....	<b>4</b>
1.1	Related documents .....	4
1.2	Abbreviations used .....	5
<b>2</b>	<b>General safety instructions</b> .....	<b>6</b>
2.1	Intended use .....	6
2.2	Improper use.....	6
2.3	Personnel qualifications .....	6
2.4	Safety instructions in this document .....	7
2.5	Adhere to the following instructions .....	7
2.6	Operator's obligations .....	9
<b>3</b>	<b>Delivery contents</b> .....	<b>10</b>
<b>4</b>	<b>Product description</b> .....	<b>11</b>
4.1	Performance description .....	11
4.2	Device description.....	11
4.3	Bypass function.....	19
4.4	Product identification.....	23
<b>5</b>	<b>Transport and storage</b> .....	<b>24</b>
5.1	Transporting the axial piston unit.....	24
5.2	Storing the axial piston unit.....	25
<b>6</b>	<b>Assembly</b> .....	<b>27</b>
6.1	Unpacking .....	27
6.2	Installation conditions.....	27
6.3	Installation position .....	29
6.4	Assembling the axial piston unit.....	33
<b>7</b>	<b>Commissioning</b> .....	<b>43</b>
7.1	First commissioning .....	44
7.2	Recommissioning after downtime .....	46
7.3	Running-in phase.....	46
<b>8</b>	<b>Operation</b> .....	<b>47</b>
<b>9</b>	<b>Maintenance and repair</b> .....	<b>48</b>
9.1	Cleaning and care.....	48
9.2	Inspection.....	48
9.3	Maintenance .....	49
9.4	Repair .....	49
9.5	Spare parts .....	49
<b>10</b>	<b>Decommissioning</b> .....	<b>50</b>
<b>11</b>	<b>Disassembly and replacement</b> .....	<b>50</b>
11.1	Required tools.....	50
11.2	Preparing for disassembly .....	50
11.3	Disassembling the axial piston unit.....	50
11.4	Preparing the components for storage or further use .....	51
<b>12</b>	<b>Disposal</b> .....	<b>52</b>
12.1	Environmental protection .....	52
<b>13</b>	<b>Extension and conversion</b> .....	<b>52</b>
<b>14</b>	<b>Troubleshooting</b> .....	<b>53</b>
14.1	How to proceed for troubleshooting .....	53
14.2	Malfunction table.....	54
<b>15</b>	<b>Technical data</b> .....	<b>56</b>
<b>16</b>	<b>Appendix</b> .....	<b>56</b>
16.1	Address directory .....	56
<b>17</b>	<b>Index</b> .....	<b>57</b>

## About this document

# 1 About this document

These instructions contain important information on the safe and appropriate assembly, transport, commissioning, maintenance, disassembly and simple troubleshooting of the A4VG series 32 axial piston variable pump.

- ▶ Read these instructions completely, especially chapter "2 General safety instructions" on page 6, before working with the A4VG axial piston variable pump.

## 1.1 Related documents

The A4VG axial piston variable pump is a system component. Also observe the instructions for the other system components.

Further information on the A4VG axial piston variable pump, its installation and operation can be found in the Rexroth documents listed in the following table.

**Table 1: Related documents**

Related documents	Contents
Order confirmation	Contains the preset technical data of your A4VG axial piston variable pump.
Installation drawing	Contains the outer dimensions, all connections and the hydraulic circuit diagram for your A4VG axial piston variable pump.
Data sheet RE 92003	Contains the permissible technical data for the A4VG series 32 axial piston variable pump.
Data sheet RE 90220	Describes the requirements for a mineral-oil based hydraulic fluid for operation with Rexroth axial piston units and assists you in selecting a hydraulic fluid for your system.
Data sheet RE 90221	Describes the requirements for an environmentally acceptable hydraulic fluid for operation with Rexroth axial piston units and assists you in selecting a hydraulic fluid for your system.
Data sheet RE 90223	Contains additional information on the use of Rexroth axial piston units with HF hydraulic fluids.
Data sheet RE 90300-03-B	Contains additional information on the use of Rexroth axial piston units at low temperatures.

Also observe the generally applicable, legal or otherwise binding regulations of the European and national legislation and the rules for the prevention of accidents and for environmental protection applicable in your country.

## 1.2 Abbreviations used

As umbrella term for "A4VG axial piston variable pump", the designation "axial piston unit" will be used in the following.

**Table 2: Abbreviations**

Abbreviation	Meaning
A4VG	Axial piston variable pump, closed circuits
DA	Automatic control, hydraulic, speed related
EP	Proportional control, electric
HD	Proportional control, hydraulic, pilot-pressure related
HW	Proportional control, hydraulic, mechanical servo
RE	Rexroth document in the English language

## 2 General safety instructions

The axial piston unit has been manufactured according to the accepted rules of current technology. There is, however, still a danger of personal injury or damage to equipment if the following general safety instructions and the warnings before the steps contained in these instructions are not complied with.

- ▶ Read these instructions completely and thoroughly before working with the axial piston unit.
- ▶ Keep these instructions in a location where they are accessible to all users at all times.
- ▶ Always include the operating instructions when you pass the axial piston unit on to third parties.

### 2.1 Intended use

Axial piston units are components in terms of the EU machine directive 98/37/EC (sub units). Axial piston units are not ready-to-use machines for the purpose of the EU machine directive. The product/component is exclusively intended for being integrated in a machine or system or for being assembled with other components to form a machine or system. The product may only be commissioned after it has been installed in the machine/system for which it is intended.

The axial piston variable pump generates, controls and regulates a hydraulic-fluid flow. It is approved for use as a hydraulic pump in hydrostatic drives in closed circuits.

- ▶ Observe the technical data, operating conditions and performance limits as specified in the data sheet and order confirmation.

The axial piston unit is not designed for private use.

Intended use includes having read and understood these instructions, especially chapter "2 General safety instructions".

### 2.2 Improper use

The axial piston unit may not be used in explosive environments.

In addition, any use of the axial piston unit other than described in chapter "2.1 Intended use" is considered to be improper.

### 2.3 Personnel qualifications

Assembly, commissioning and operation, disassembly, maintenance and repair require basic mechanical, hydraulic and electrical knowledge, as well as knowledge of the appropriate technical terms. For transporting and handling the product, additional knowledge is necessary with regard to working with a crane and the corresponding attachment equipment. In order to ensure operating safety, these activities may therefore only be carried out by qualified personnel or an instructed person under the direction and supervision of qualified personnel.

Qualified personnel are those who can recognize possible hazards and institute the appropriate safety measures due to their professional training, knowledge, and experience, as well as their understanding of the relevant conditions pertaining to the work to be done. Qualified personnel must observe the rules relevant to the subject area.

## 2.4 Safety instructions in this document





In this manual, there are safety instructions before the steps whenever there is a danger of personal injury or damage to equipment. The measures described to avoid these hazards must be observed.

Safety instructions are set out as follows:

SIGNAL WORD!	Type of danger!
	Consequences ▶ Precautions

- **Safety sign:** (warning triangle): draws attention to the danger
- **Signal word:** identifies the degree of the danger
- **Type of danger:** identifies the type or source of the danger
- **Consequences:** describes what occurs if the safety instructions are not complied with
- **Precautions:** states how the danger can be avoided.

The signal words have the following meaning:

Signal word	Application
<b>DANGER!</b> 	Indicates an <b>imminently</b> hazardous situation which, if not avoided, will certainly result in death or serious injury.
<b>WARNING!</b> 	Indicates a <b>potentially</b> hazardous situation which, if not avoided, could result in death or serious injury.
<b>CAUTION!</b> 	Indicates a <b>potentially hazardous</b> situation which, if not avoided, could result in minor or moderate injury or damage to equipment.
	If this information is disregarded, the operating procedure may be impaired.

## 2.5 Adhere to the following instructions

### General instructions

- Observe the regulations for accident prevention and environmental protection for the country where the product is used and at the workplace.
- Only use Rexroth axial piston units in good technical order and condition.
  - Inspect the product for obvious defects.
- Do not modify or retrofit the axial piston unit.
- Only use the product within the performance range provided in the technical data.
- Persons who assemble, commission, operate, disassemble or maintain Rexroth products must not consume any alcohol, drugs or pharmaceuticals that may affect their ability to respond.

**General safety instructions**

- The warranty only applies to the delivered configuration.
- The warranty is rendered void if the product is incorrectly assembled, commissioned or operated, as well as if not used as intended and/or handled improperly.
- Do not expose the product to any mechanical loads under any circumstances. Never use the product as a handle or step. Do not place/lay any objects on it.
- The noise emission of axial piston units depends on speed, operating pressure and installation conditions. The sound pressure level may rise above 70 dBA during normal operating conditions. This can cause hearing damage.
  - Always wear hearing protection while working in the vicinity of the operating axial piston unit.
- The axial piston unit heats up considerably during operation. The solenoids of the axial piston unit get so hot during operation that you may burn yourself:
  - Allow the axial piston unit to cool down sufficiently before touching it.
  - Wear heat-resistant protective clothing, e.g. gloves.

**During transport** • Make certain that the lifting gear has adequate lifting capacity. The weight can be found in chapter "5 Transport and storage".

**During assembly** • Before assembling, make sure that all fluids have been completely removed from the axial piston unit to prevent mixing with the hydraulic fluid used in the system.

• Make sure the relevant system component is not under pressure or voltage before assembling the product or when connecting and disconnecting plugs. Protect the system against being switched on.

• Lay cables and lines so that they cannot be damaged and no one can trip over them.

• Before commissioning, make sure that all hydraulic connections are tight and that all the connection seals and plugs are installed correctly to ensure that they are leakproof and fluids and contaminants are prevented from penetrating the product.

• When assembling, provide for absolute cleanliness in order to prevent contaminants such as welding beads or metal cuttings from getting into the hydraulic lines and causing product wear or malfunctions.

**During commissioning** • Ensure that all electrical and hydraulic connections and ports are occupied or plugged. Only commission a completely installed product.

**During cleaning** • Plug all openings with the appropriate protective equipment in order to prevent detergents from penetrating the system.

• Never use solvents or aggressive detergents. Use only water and, if necessary, a mild detergent to clean the axial piston unit.

• Do not point a high-pressure cleaner at sensitive components such as, e.g. shaft seal ring, electrical connections and electrical components.

**During maintenance and repair** • Perform the prescribed maintenance work at the intervals specified in the operating instructions (see chapter "9.3 Maintenance").

• Make sure that no lines, connections or components are disconnected as long as the system is under pressure. Protect the system against being switched on.

**During disposal** • Dispose of the product and the hydraulic fluid in accordance with the currently applicable national regulations in your country.



## 2.6 Operator's obligations

The operator of the axial piston unit from Rexroth must provide personnel training on a regular basis regarding the following subjects:

- Observation and use of the operating instructions and the legal regulations.
- Intended use and operation of the axial piston unit.
- Observation of the instructions from the factory security offices and of the work instructions from the operator.



Rexroth offers training support for special fields.

You can find an overview of the training contents on the Internet at:

<http://www.boschrexroth.de/didactic>.

### 3 Delivery contents

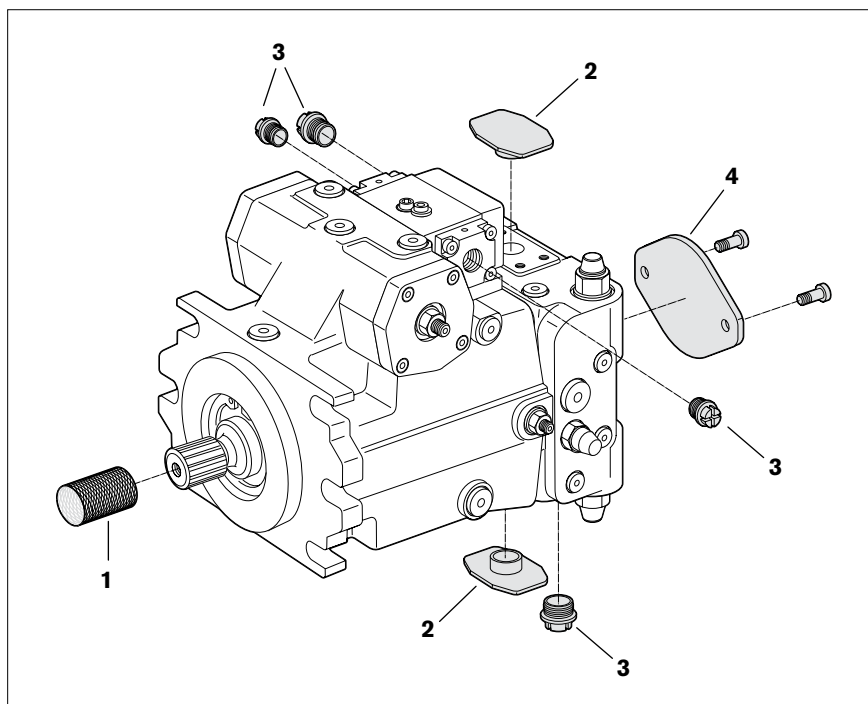

Fig. 1: Axial piston unit

Included in the delivery contents are:

- 1 Axial piston unit

The following parts are also assembled on delivery:

- Transport protection for drive shaft end (1).
- Protective covers (2).
- Plastic plugs / locking screws (3).
- Flange cover and fixing screws (4) (optional for versions with through drive).

## 4 Product description

### 4.1 Performance description

The axial piston variable pump generates, controls and regulates a hydraulic-fluid flow. It is designed for mobile applications such as construction machinery.

Refer to the data sheet and order confirmation for the technical data, operating conditions and operating limits of the axial piston unit.

### 4.2 Device description

The A4VG is an axial piston variable pump with swashplate design for hydrostatic drives in closed circuits. Flow is proportional to drive speed and displacement. The flow can be steplessly changed by controlling the swashplate (11).

#### Closed circuit

A hydraulic system is considered to be closed if the hydraulic fluid which flows back from the consumer is directed directly back to the pump. Here, there is a high-pressure side and a low-pressure side depending on the load direction (output torque on the consumer).

#### 4.2.1 Assembly of the axial piston unit

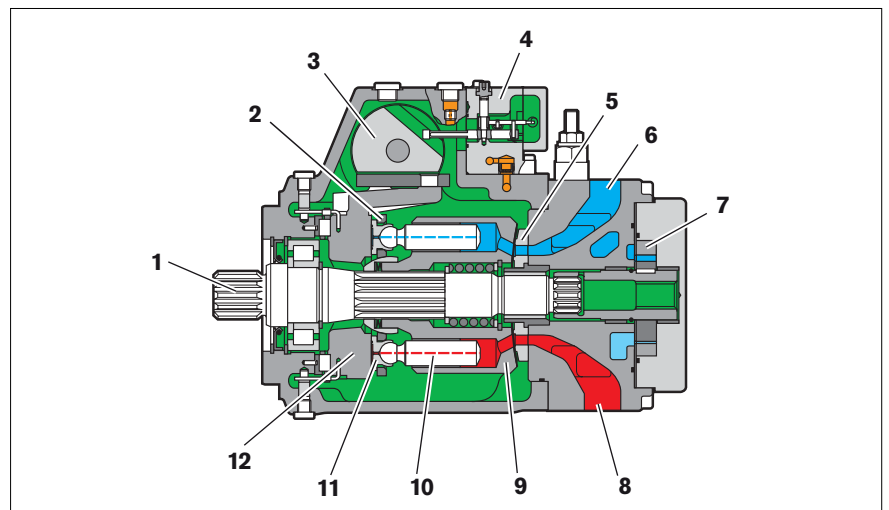

Fig. 2: Assembly of the A4VG series 32

1 Drive shaft	5 Control plate	10 Piston
2 Retaining plate	6 Low-pressure side	11 Slipper pad
3 Stroke piston	7 Auxiliary pump	12 Swashplate
4 Controller (using the EP as an example here)	8 High-pressure side	
	9 Cylinder	

For axial piston units with swashplate design, the pistons (10) are arranged axially with respect to the drive shaft (1). They are guided in the rotating cylinder (9) and support themselves with the slipper pads (11) on the non-rotating swashplate (12). The drive shaft (1) and cylinder (9) are connected to one another by means of gearing.

## Product description

## 4.2.2 Functional description

<b>Pump</b>	Torque is applied to the drive shaft (1) by an engine. The cylinder (9) turns with the drive shaft, turning with it the pistons (10). On each rotation, the pistons perform a stroke movement which is defined by the pitch of the swashplate (12). The slipper pads (11) are held on and guided along the glide surface of the swashplate by the retaining plate (2). During a rotation, each piston moves over the bottom and top dead centers back to its initial position. During this action, the fluid volume defined by the piston surface and the stroke is fed in or removed through the two control slits in the control plate (5). On the low-pressure side, (6) fluid flows into the enlarging piston chamber – in a closed circuit this is supported by the return and boost pressures. At the same time, on the high-pressure side (8) the fluid is pushed out of the cylinder chamber into the hydraulic system by the pistons.
<b>Pressure cut-off</b>	The operating pressure is limited by the pressure cut-off. The pressure cut-off corresponds to a pressure regulator which reduces the pump capacity once the set specified pressure value is reached so that the set pressure is maintained but not exceeded.
<b>High-pressure safeguarding</b>	The pressure spikes which occur during very rapid swiveling operations as well as the maximum pressure are safeguarded by the superordinate high-pressure relief valves. These valves open if the set value is exceeded, thereby depressurizing the low-pressure side. The fluid quantity remains constant in the closed circuit. The leakage at the pump and motor is replaced by the auxiliary pump (7).
<b>Auxiliary pump</b>	The auxiliary pump continuously supplies a sufficient volume of fluid (boost volume) from a small tank to the low-pressure side of the closed circuit via a check valve to replenish the internal leakage of the variable pump and consumer.
<b>Neutral valve (optional)</b>	The optional neutral valve interrupts the active control pressure and joins the two positioning chambers for pressure equalization. The springs in the positioning chambers move the stroke piston (3) towards the middle position (neutral position). The reset function is influenced by the current operating pressure and the speed.  Switching off the control pressure and a bypass function for the two positioning chambers does not ensure that the pump moves to the middle position (neutral position).  Use an appropriate emergency-off device to ensure that the drive can be brought to a safe position at any time. The device or system operator is responsible for the installation of a proper emergency-off device.  The following warning notice applies to all axial piston units with the HD and EP control units:

**CAUTION!****The spring return in the control unit is not a security device.**

The slide valve of the control unit can be blocked in an undefined position by internal contamination (impure hydraulic fluid, abrasion or residual contamination from system components). As a result, the axial piston unit can no longer supply the flow specified by the operator.

- ▶ Properly install an emergency-off function to ensure that the driven consumer can be brought to a safe position (e.g. immediate stop).
- ▶ Maintain the specified cleanliness level 20/18/15 (< 90 °C) or 19/17/14 in accordance with ISO 4406.

**Control** The swivel angle of the swashplate (**12**) is infinitely variable. By changing the swivel angle, the piston stroke and, therefore, the displacement change. The swivel angle is controlled hydraulically via the stroke piston (**3**). The swashplate is mounted for easy motion in swivel bearings and the neutral position spring centered. Increasing the swivel angle increases the displacement; reducing the angle results in a corresponding reduction in displacement.

If the swashplate is not swiveled out, the displacement is equal to zero. Various controllers are available depending on requirements.



Additional information on the control devices, such as the circuit diagram or characteristics, can be found in technical data sheet RE 92003.

**Product description****4.2.3 Control units****NV – version without control unit**

The mounting surface for the control unit is machined and is sealed with the standard seal for control units and a cover plate. This version is ready for retrofitting to control units (HD, HW, EP, EZ). When used directly for "DA" control and in combinations with "DA" control, the appropriate adjustments must be made to the spring assembly of the control cylinder and control plate.

**DG – hydraulic control,  
direct operated**

The stroke cylinder of the pump is directly supplied with control pressure by switching a pilot pressure on or off at ports **X<sub>1</sub>** or **X<sub>2</sub>**. In this way, the swashplate and thus the displacement can be adjusted between  $V_g = 0$  and  $V_{g \max}$ . A different flow direction is associated with each port.

**EZ – electric two-point control,  
with switching solenoid**

By energizing or de-energizing a control current to either switching solenoid a or b, the stroke cylinders of the pump are supplied with control pressure by the EZ control unit. In this way, the swashplate and thus the displacement is adjustable without intermediate settings between  $V_g = 0$  and  $V_{g \max}$ . A different flow direction is associated with each switching solenoid.

**HD – proportional control, hydraulic, pilot-pressure related**

Depending on the pressure difference of the pilot pressure  $p_{St}$  in the two control lines (ports  $Y_1$  and  $Y_2$ ), the stroke cylinder of the pump is supplied with control pressure via the HD control unit. Thus, the swashplate – and, therefore, the displacement – are infinitely adjustable. A different flow direction is associated with each control line.

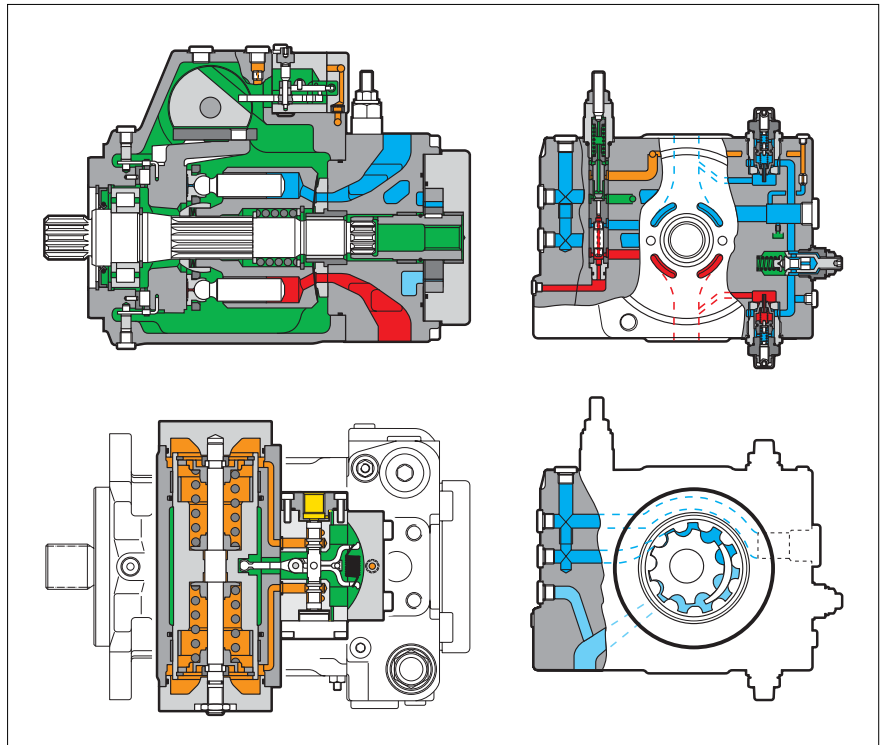

**Fig. 3: Cut-away view of A4VG with hydraulic proportional control, pilot-pressure related (shown is size 71–180)**

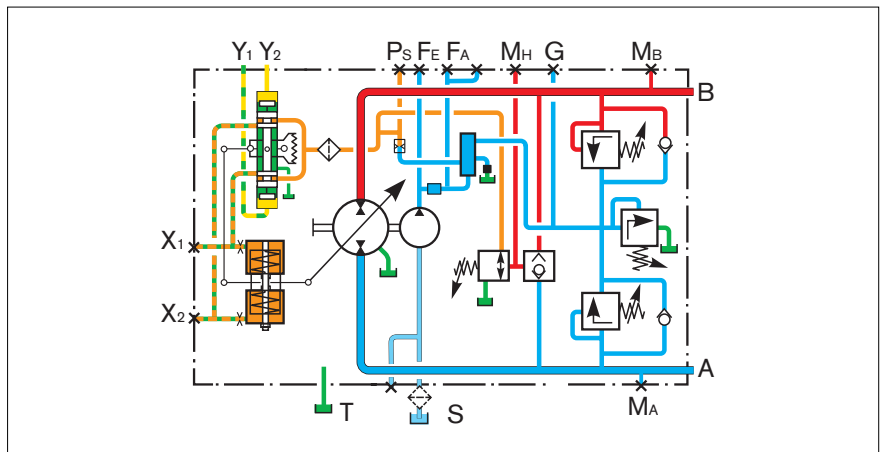

**Fig. 4: Hydraulic circuit diagram of A4VG with hydraulic proportional control**

- |  |   |  |
|--|---|--|
| <span style="color: red;">█</span> High pressure | <span style="color: lightblue;">█</span> Suction pressure | <span style="color: orange;">█</span> Control pressure |
| <span style="color: blue;">█</span> Low pressure | <span style="color: green;">█</span> Case drain pressure  | <span style="color: yellow;">█</span> Pilot pressure   |

Product description

**HW – proportional control,  
hydraulic, mechanical servo**

Depending on the swivel angle of the control lever and the actuating direction, the stroke cylinder of the pump is supplied with control pressure via the HW control unit. Thus, the swashplate – and, therefore, the displacement – are infinitely adjustable. A different actuating direction is associated with each direction of control lever actuation.

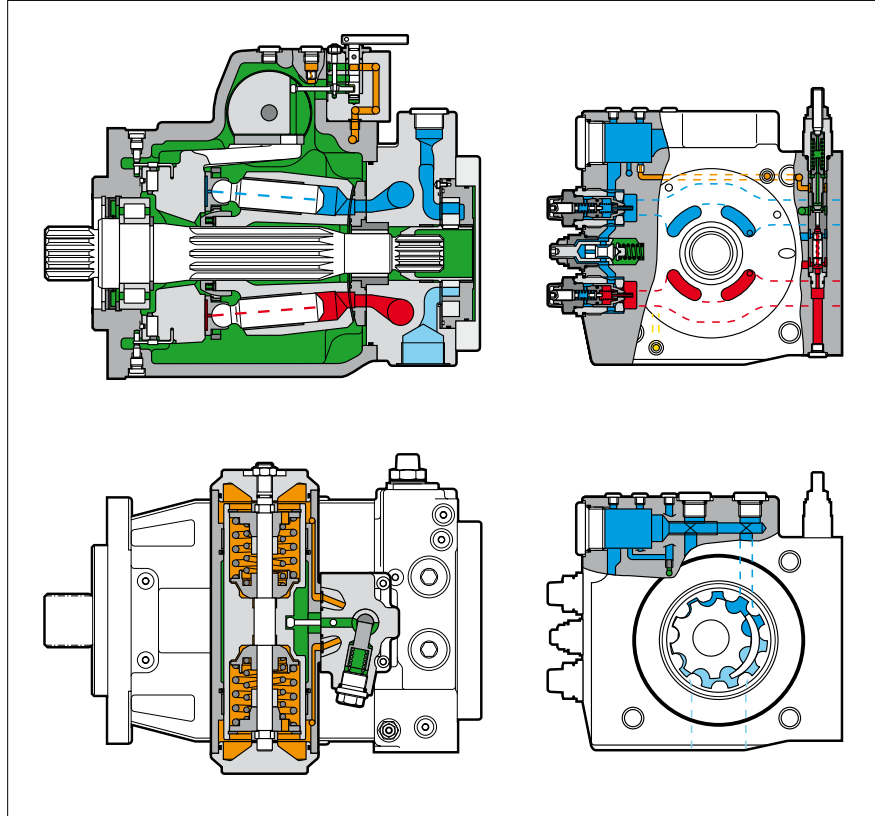

Fig. 5: Cut-away view of A4VG with hydraulic proportional control, mechanical servo (shown is size 250)

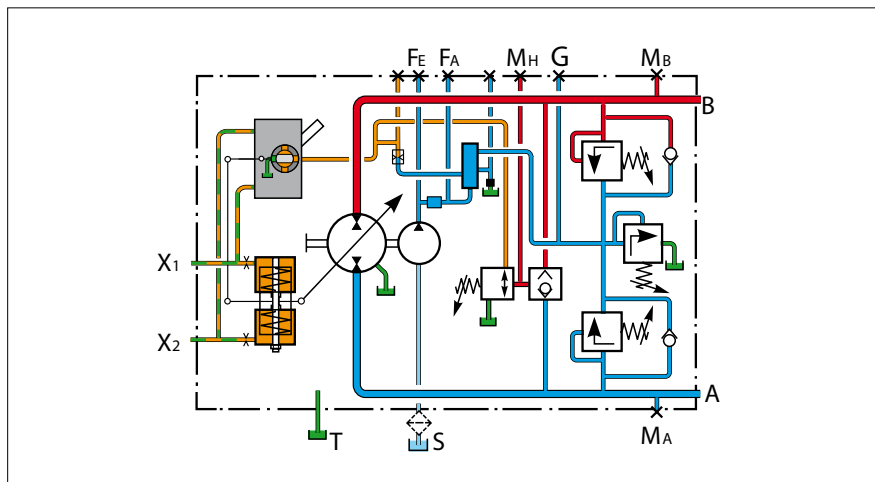

Fig. 6: Hydraulic circuit diagram of A4VG with hydraulic proportional control

- |  |   |  |
|--|---|--|
| <span style="color: red;">█</span> High pressure | <span style="color: lightblue;">█</span> Suction pressure | <span style="color: orange;">█</span> Control pressure |
| <span style="color: blue;">█</span> Low pressure | <span style="color: green;">█</span> Case drain pressure  |  |



**EP – proportional control, electric**

Depending on the preselected current "I" at the two proportional solenoids, the stroke cylinder of the pump is supplied with control pressure via the EP controller. Thus, the swashplate – and, therefore, the displacement – are infinitely adjustable. A different flow direction is associated with each proportional solenoid.

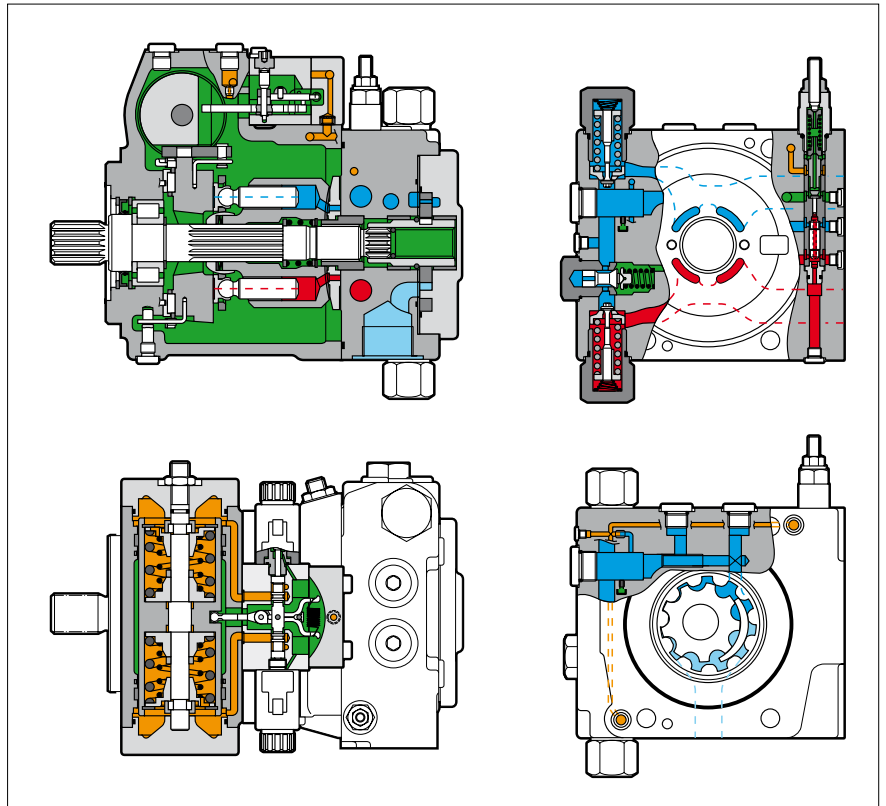

Fig. 7: Cut-away view of A4VG with electric proportional control (shown is size 28)

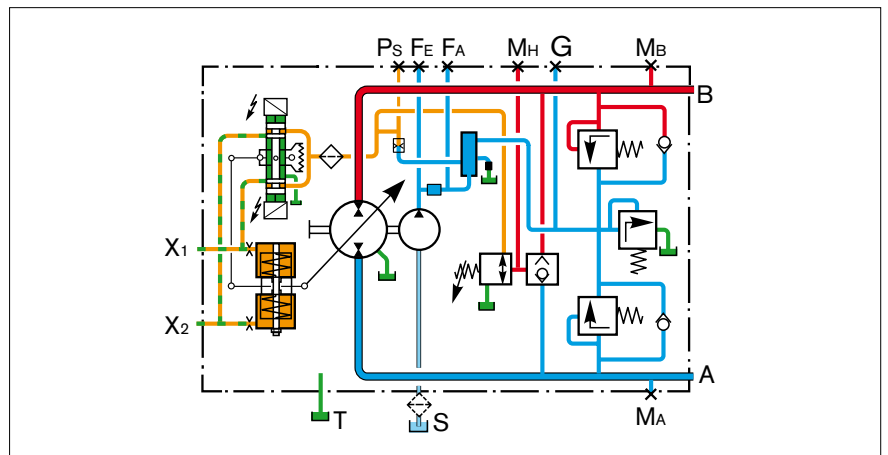

Fig. 8: Hydraulic circuit diagram of A4VG with electric proportional control

- |  |   |  |
|--|---|--|
| <span style="color: red;">█</span> High pressure | <span style="color: lightblue;">█</span> Suction pressure | <span style="color: orange;">█</span> Control pressure |
| <span style="color: blue;">█</span> Low pressure | <span style="color: green;">█</span> Case drain pressure  |  |

Product description

**DA – automatic control, hydraulic, speed related**

Depending on the drive speed, the DA control unit generates a pilot pressure which charges the stroke cylinder of the pump with control pressure via a 4/3-directional valve, allowing the swashplate – and, therefore, the displacement – to be infinitely adjusted. Each flow direction is assigned a switching solenoid on the 4/3-directional valve.

You can find details on DA closed loop control in operating instructions "Hydrostatic travel drive with DA closed loop control" – RE 90 330-01-B and in RE 90 330-03-B (functional description and project planning notes).

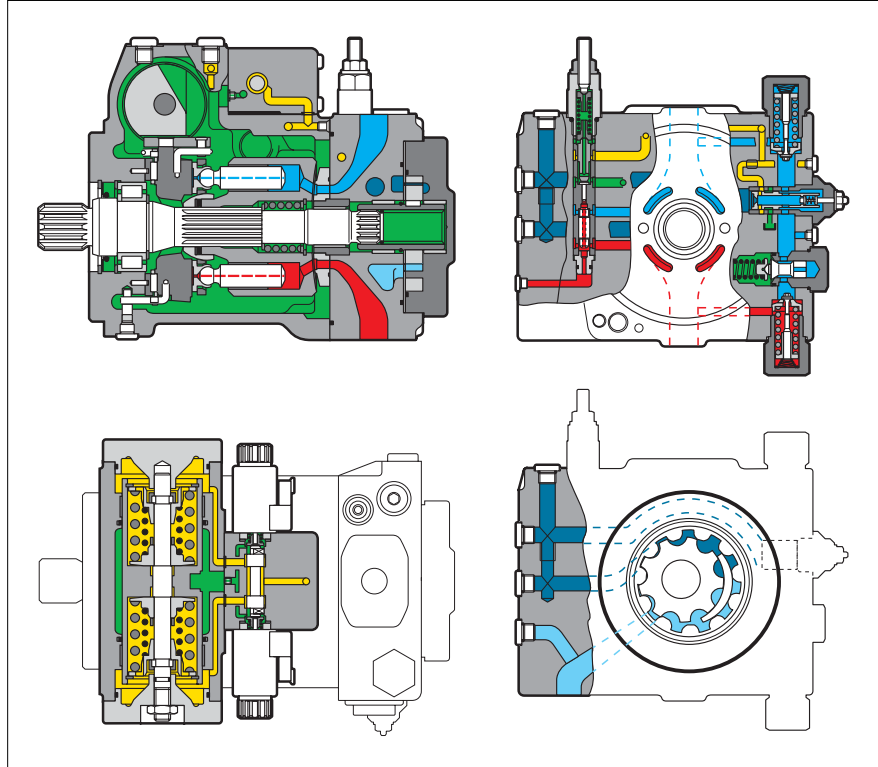

**Fig. 9: Cut-away view of A4VG with automatic control, hydraulic, speed related (shown is size 40/56)**

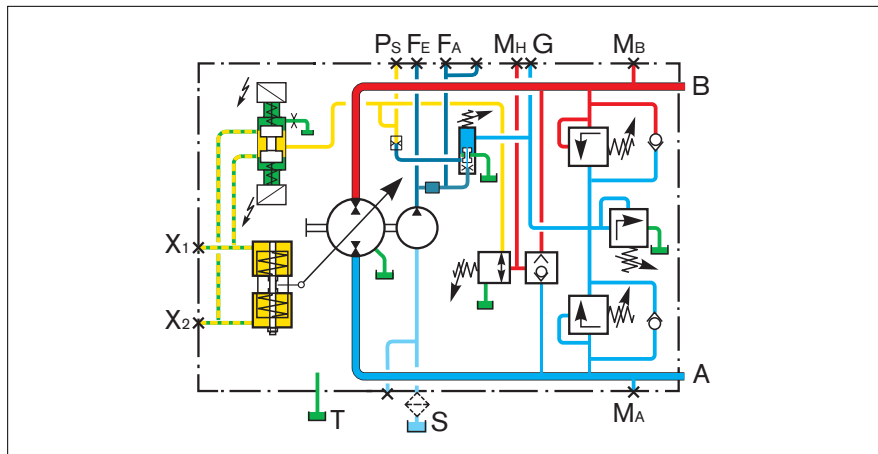

**Fig. 10: Hydraulic circuit diagram of A4VG with automatic control, hydraulic, speed related**

- |  |   |  |
|--|---|--|
| <span style="color: red;">█</span> High pressure | <span style="color: lightblue;">█</span> Suction pressure | <span style="color: yellow;">█</span> Pilot pressure |
| <span style="color: blue;">█</span> Low pressure | <span style="color: green;">█</span> Case drain pressure  |  |

## 4.3 Bypass function

For vehicles with hydrostatic travel drive, as long as there is no downstream mechanical interruption of the drive train (switch to idle/free running), the flow can be altered using a bypass function in order to tow the vehicle out of the immediate danger zone.

Turning the corresponding screw allows the hydraulic fluid to flow freely.

### 4.3.1 Bypass function, sizes 28 to 56



The standard version of the A4VG variable pump, sizes 28–56, has **no** high-pressure relief valves with bypass function. If necessary, this must be specified when ordering.

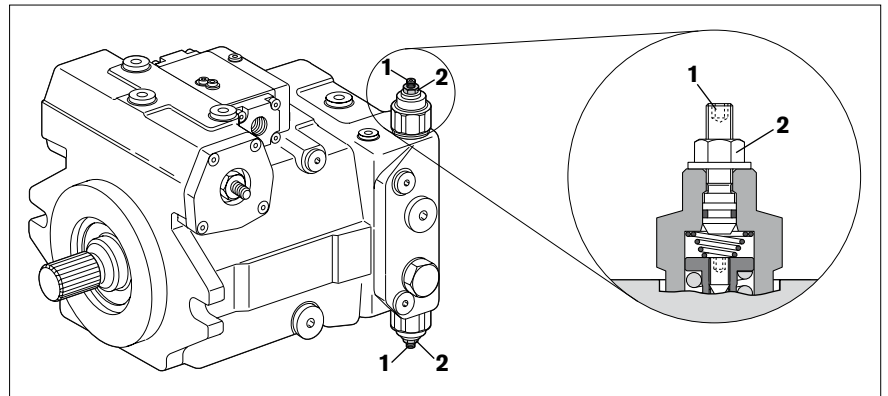

Fig. 11: Activating the bypass function, sizes 28 to 56

#### Activating the bypass function

To activate the bypass function:

1. Switch off the combustion engine.
2. Loosen the lock nut (2) by turning counter-clockwise one half rotation with a hex wrench (WAF 13).
3. Use an Allen key (WAF 4) to screw in the screw (1) clockwise until the screw (1) is against the spring disc. This is apparent by the increased resistance. Then screw the screw (1) one half turn into the spring disc.
4. Tighten the lock nut (2) clockwise with a torque of 22 Nm.

#### Towing speed

The maximum towing speed is dependent on the gear ratio in the vehicle and must be calculated by the vehicle manufacturer. The corresponding flow of  $Q = 30 \text{ l/min}$  must not be exceeded.

#### Towing distance

The vehicle may only be towed out of the immediate danger zone.

#### CAUTION!



#### Risk of damage!

Higher towing speeds and longer towing distances result in impermissible heat generation and insufficient lubrication. This damages the axial piston unit.

- ▶ Only tow the vehicle out of the immediate danger zone.

Product description

**CAUTION!**



**Risk of damage!**

During and after towing, the axial piston units are hot.  
 ▶ Wear protective clothing.

**Deactivating the bypass function**

To deactivate the bypass function:

1. Immediately following towing, switch off the bypass function.
2. Restore the function of the high-pressure relief valve. To do this, perform the settings made under item "Activating the bypass function" in the reverse order: Loosen the lock nut (2) with a hex wrench (WAF 13), then turn the screw (1) counter-clockwise with an Allen key (WAF 4) to the stop.
3. Retighten the lock nut (2), turning clockwise with a torque of 22 Nm

**CAUTION!**



**Risk of damage!**

While towing with the bypass function activated, the closed hydraulic circuit empties itself. This can result in unintended functions when restarting the travel drive.

- ▶ Start the travel drive only after completely filling and air bleeding the hydraulic circuit (see "7.1 First commissioning").

**4.3.2 Bypass function, sizes 71, 90**

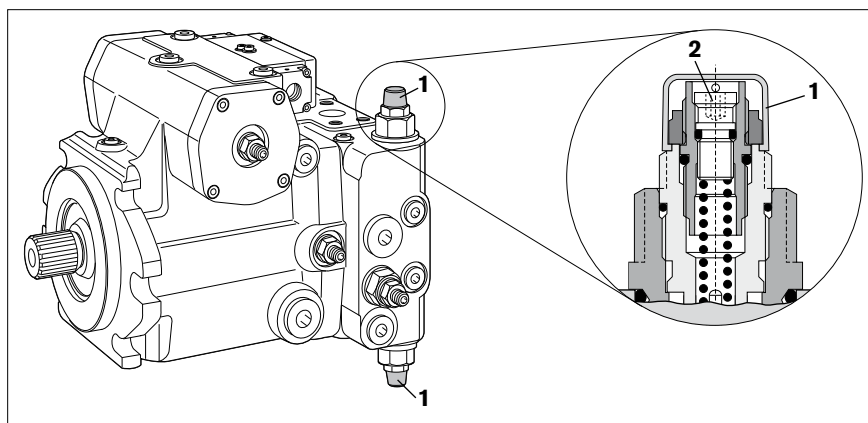

Fig. 12: Activating the bypass function, sizes 71, 90

**Activating the bypass function**

To activate the bypass function:

1. Switch off the combustion engine.
2. Remove the plastic protective cap (1) on the high-pressure relief valve with a suitable tool (e.g. gripper).
3. Loosen the one screw (2) by turning counter-clockwise two rotations with an Allen key (WAF 5).

The plastic protective cap is destroyed when removing.



<b>Towing speed</b>	The maximum towing speed is dependent on the gear ratio in the vehicle and must be calculated by the vehicle manufacturer. The corresponding flow of $Q = 50 \text{ l/min}$ must not be exceeded.
<b>Towing distance</b>	The vehicle may only be towed out of the immediate danger zone.

**CAUTION!****Risk of damage!**

Higher towing speeds and longer towing distances result in impermissible heat generation and insufficient lubrication. This damages the axial piston unit.

- ▶ Only tow the vehicle out of the immediate danger zone.

**CAUTION!****Risk of damage!**

During and after towing, the axial piston units are hot.

- ▶ Wear protective clothing.

**Deactivating the bypass function**

To deactivate the bypass function:

1. Immediately following towing, switch off the bypass function.
2. Restore the function of the high-pressure relief valve. To do this, tighten the screw (2) with an Allen key (WAF 5) by turning clockwise with a torque of  $10 \pm 1 \text{ Nm}$ .
3. Refit the screw (2) with a protective cap to prevent unauthorized changes to the position of the pressure-relief valve.

**CAUTION!****Risk of damage!**

While towing with the bypass function activated, the closed hydraulic circuit empties itself. This can result in unintended functions when restarting the travel drive.

- ▶ Start the travel drive only after completely filling and air bleeding the hydraulic circuit (see "7.1 First commissioning").

**4.3.3 Bypass function, sizes 125 to 250**

Fig. 13: Activating the bypass function, sizes 125 to 250

## Product description

### Activating the bypass function

To activate the bypass function:

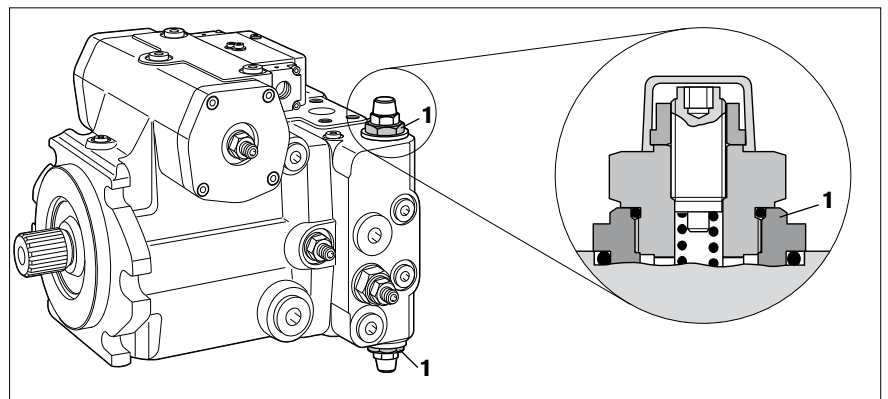
1. Switch off the combustion engine.
2. Loosen the screw (1) by turning counter-clockwise one rotation with a hex wrench (WAF 36).



An optimal seal is not ensured if the high-pressure relief valve is loosened. If hydraulic fluid leaks from the high-pressure relief valve, clear away the fluid immediately and clean the valve.

### Towing speed

The maximum towing speed is dependent on the gear ratio in the vehicle and must be calculated by the vehicle manufacturer. The corresponding flow of  $Q = 100 \text{ l/min}$  must not be exceeded.

### Towing distance

The vehicle may only be towed out of the immediate danger zone.

#### CAUTION!



#### Risk of damage!

Higher towing speeds and longer towing distances result in impermissible heat generation and insufficient lubrication. This damages the axial piston unit.

- ▶ Only tow the vehicle out of the immediate danger zone.

#### CAUTION!



#### Risk of damage!

During and after towing, the axial piston units are hot.

- ▶ Wear protective clothing.

### Deactivating the bypass function

To deactivate the bypass function:

1. Immediately following towing, switch off the bypass function.
2. Restore the function of the high-pressure relief valve. To do this, tighten the screw (1) with a hex wrench (WAF 36) by turning clockwise with a torque of  $200 \pm 10 \text{ Nm}$ .

#### CAUTION!



#### Risk of damage!

While towing with the bypass function activated, the closed hydraulic circuit empties itself. This can result in unintended functions when restarting the travel drive.

- ▶ Start the travel drive only after completely filling and air bleeding the hydraulic circuit (see "7.1 First commissioning").

#### 4.4 Product identification

The axial piston unit can be identified with the name plate. The following example shows an A4VG name plate:

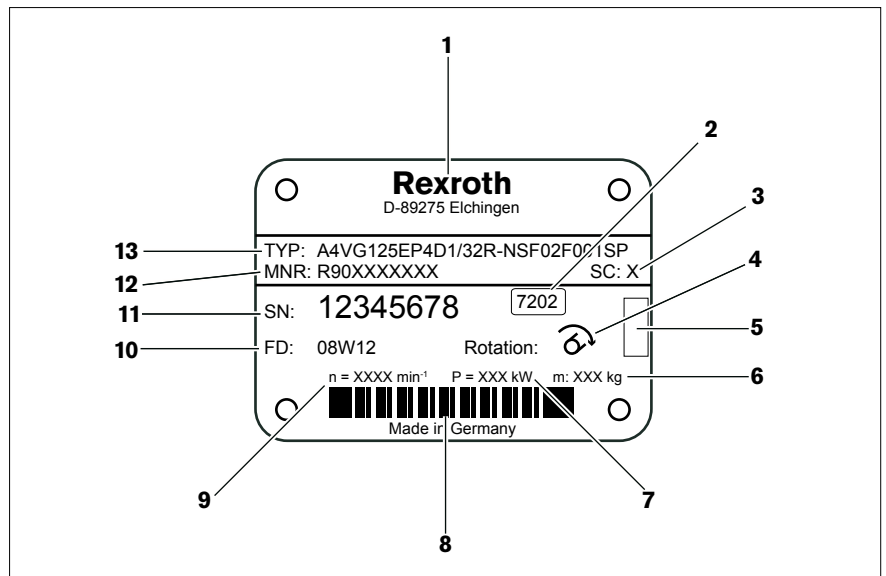

Fig. 14: Name plate A4VG

- |   |  |    |  |
|---|--|----|--|
| 1 | Manufacturer   | 8  | Barcode                                  |
| 2 | Internal plant designation                                       | 9  | Rotational speed                         |
| 3 | Sample category (optional)                                       | 10 | Production date                          |
| 4 | Direction of rotation (looking at drive shaft) – here: clockwise | 11 | Serial number                            |
| 5 | Specified area for test stamp                                    | 12 | Material number of the axial piston unit |
| 6 | Weight (optional)  | 13 | Ordering code                            |
| 7 | Power  |    |  |

## 5 Transport and storage

### 5.1 Transporting the axial piston unit

#### CAUTION!



#### Risk of damage!

Hitting or impulsive forces on the drive shaft can damage the axial piston unit.

- ▶ Do not hit the coupling or drive shaft of the axial piston unit.
- ▶ Do not set/place the axial piston unit on the drive shaft.
- ▶ Details on the permissible axial and radial forces can be found in the data sheet.

Axial piston units can be transported with a forklift truck or with a lifting device.

- ▶ Make certain that the forklift truck or lifting device has adequate lifting capacity.

#### Dimensions and weights

Table 3: Dimensions and weights

Size		28	40	56	71	90	125	180	250
Weight	kg	29	31	38	50	60	80	101	156
Width	mm	The dimensions vary with the unit type. The values applicable to your axial piston unit can be found in the installation drawing.							
Height	mm								
Depth	mm								

The weight specifications may vary depending on the unit type. The exact weight can be found on the name plate.

#### 5.1.1 Transporting with lifting device

For transporting, the axial piston unit can be connected to a lifting device via a ring screw or a lifting strap.

#### Transport with ring screw

The drive shaft can be used to transport the axial piston unit as long as only outward axial forces occur. Thus, you can suspend the axial piston unit from the drive shaft.

- ▶ To do this, screw a ring screw completely into the thread on the drive shaft. The size of the thread is stated in the installation drawing.
- ▶ Make sure that each ring screw can bear the total weight of the axial piston unit plus approx. 20 %.

You can hoist the axial piston unit as shown in Fig. 15 with the ring screw screwed into the drive shaft without any risk of damage.

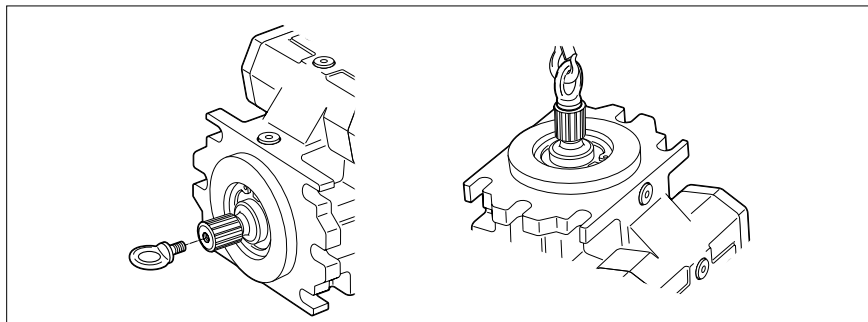

Fig. 15: Fixing the ring screw



**Transport with lifting strap**

- ▶ Place the lifting strap around the axial piston unit in such a way that it passes over neither the attachment parts (e.g. valves) nor such that the axial piston unit is hung from attachment parts (see Fig. 16).

**WARNING!****Risk of injury!**

During transport with lifting device, the axial piston unit can fall out of the lifting strap and cause injuries.

- ▶ Hold the axial piston unit with your hands to prevent it from falling out of the lifting strap.
- ▶ Use the widest possible lifting strap.

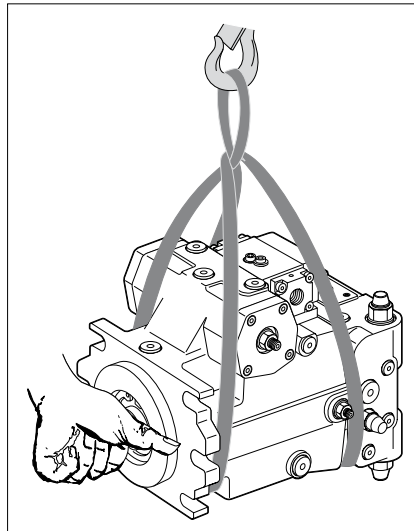

Fig. 16: Transport with lifting strap

## 5.2 Storing the axial piston unit

**Requirement**

- The storage areas must be free of corrosive materials and gasses.
- The storage areas must be dry.
- The ideal temperature for storage lies between +5 °C and +20 °C.
- Avoid intense lights.
- Do not stack axial piston units and store them shock-proof.
- For other storage conditions, see Table 4.

- ▶ Check the axial piston unit monthly to ensure proper storage.

**After delivery**

The axial piston units are provided ex-works with a corrosion protection packaging (corrosion protection film).

Listed in the following table are the maximum permissible storage times for an originally packed axial piston unit.

**Table 4: Storage time with factory corrosion protection**

Storage conditions	Standard corrosion protection	Long-term corrosion protection
Closed, dry room, uniform temperature between +5 °C and +20 °C. Undamaged and closed corrosion protection film.	Maximum 12 months	Maximum 24 months

## Transport and storage



The warranty is rendered void if the requirements and storage conditions are not adhered to or after expiration of the maximum storage time (see Table 4).

Procedure after expiration of the maximum storage time:

1. Check the entire axial piston unit for damage and corrosion prior to installation.
2. Check the axial piston unit for proper function and leaks during a test run.
3. Replace the shaft seal ring if the storage time of 24 months is exceeded.



After expiration of the maximum storage time, we recommend that you have the axial piston unit inspected by your responsible Rexroth Service partner.

In the event of questions regarding spare parts, contact your responsible Rexroth Service partner or the service department of the manufacture's plant for the axial piston unit, see chapter "9.5 Spare parts" for further information.

### After disassembly

If a dismantled axial piston unit is to be stored, it must be conserved against corrosion for the duration of the storage.



The following instructions only refer to axial piston units which are operated with a mineral-oil based hydraulic fluid. Other hydraulic fluids require conservation methods that are specifically designed for them. In such a case, consult with Rexroth Service (see chapter "9.5 Spare parts" for address).

Rexroth recommends the following procedure:

1. Clean the axial piston unit, see chapter "9.1 Cleaning and care" for further information.
2. Completely empty the axial piston unit.
3. For storage time up to 12 months: Moisten the inside of the axial piston unit with mineral oil and fill with approx. 100 ml mineral oil.  
For storage time up to 24 months: Fill the axial piston unit with corrosion protection VCI 329 (20 ml).  
Fill via case drain port **T<sub>1</sub>** or **T<sub>2</sub>**, see chapter "6.4 Assembling the axial piston unit", Fig. 22 to 25.
4. Seal all ports airproof.
5. Moisten the unpainted surfaces of the axial piston unit with mineral oil.
6. Package the axial piston unit airproof together with desiccant in corrosion protection film.
7. Store the axial piston unit so that it is protected against jolts.  
See "Requirement" in this chapter for further conditions.

## 6 Assembly

Prior to assembly, the following documents must be available:

- Installation drawing for the axial piston unit (available from Rexroth),
- Hydraulic circuit diagram for the axial piston unit (in the installation drawing),
- Hydraulic circuit diagram for the system (available from the system manufacturer),
- Order confirmation (contains the preset data of the axial piston unit),
- Data sheet for the axial piston unit (contains the technical data).

### 6.1 Unpacking

The axial piston unit is delivered in a corrosion protection film made of polyethylene material.

- ▶ Dispose of the packaging according to the national regulations of your country.

---

**CAUTION!****Risk of parts falling out!**

If the packaging is not opened correctly, parts may fall out and damage the parts or even result in injury.

- ▶ Place the packaging on a flat and solid surface.
  - ▶ Only open the packaging from the top.
- 

### 6.2 Installation conditions

- The installation location and position of the axial piston unit essentially determine the procedures during installation and commissioning (such as when filling the axial piston unit).
- Note that you can expect certain installation positions to affect the control device. Because of gravity, dead weight and case pressure, minor characteristic displacements and actuating time changes may occur.
  - ▶ Adhere to all limits specified in the data sheet regarding temperature, viscosity, cleanliness of the hydraulic fluid.
  - ▶ Make certain that the case of the axial piston unit is filled with hydraulic fluid during commissioning and operation. This is also to be observed following relatively long standstill periods as the axial piston unit may empty via the hydraulic lines.
  - ▶ The case drain fluid in the case interior must be directed to the tank via the highest case drain port. Use the line size which is appropriate for the port.
  - ▶ Avoid using a check valve in the case drain line (exception: see "Above-tank installation" in chapter "6.3 Installation position").
  - ▶ To achieve favorable noise values, decouple all connecting lines from all vibration-capable components (e.g. tank) using elastic elements.

## Assembly

- ▶ Make certain that the suction line, case drain line, and return line flow into the tank below the minimum fluid level in all operational states.

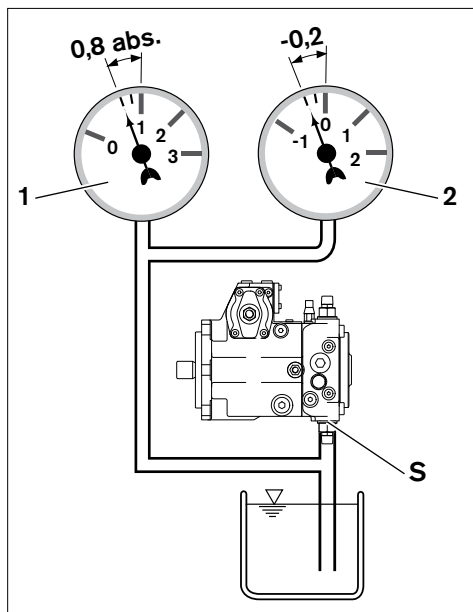

Fig. 17: Suction pressure

- 1 Absolute pressure gauge
- 2 Standard pressure gauge

- ▶ Make certain that a minimum suction pressure of 0.8 bar absolute is present at port "S" during operation and on cold starts in all installation positions and installation locations for the axial piston pump, see Fig. 17. See data sheet for additional values.
- ▶ Absolute cleanliness is required. The axial piston unit must be installed in a clean condition. Contamination of the hydraulic fluid can have a considerable impact on the service life of the axial piston unit.
- ▶ Do not use any cotton waste or linty cloths for cleaning.
- ▶ Use suitable liquid detergents to remove lubricants and other difficult-to-remove contamination. Detergents must not penetrate the hydraulic system.

---

**CAUTION!**

**Risk of damage by air inclusions!**

An air pocket in the area near the bearings will damage the axial piston unit.

- ▶ Make certain that the case is completely filled with hydraulic fluid during commissioning and during operation with the "drive shaft upward" installation position.
  - ▶ During commissioning and during operation, the suction line must be filled with hydraulic fluid.
- 

**CAUTION!**

**Risk of damage by hydraulic fluid loss!**

With above-tank installation, the case interior may drain via the case drain line after longer standstill periods (air enters via the shaft seal ring) or via the service line (gap leakage). The bearings are thus insufficiently lubricated when the pump is restarted.

- ▶ Check the hydraulic fluid level in the case interior regularly; if necessary, recommission.
-

### 6.3 Installation position

The following installation positions are permissible. The shown piping layout illustrates the basic layout.



"Shaft upward" installation position (positions 4 and 8):

For the "shaft upward" installation position, you will also need the additional R<sub>1</sub> air bleed port in the flange area for sizes 71-180. This port is not included in the standard version and **must** be specified in plain text when ordering.

### 6.3.1 Below-tank installation (standard)

Below-tank installation is when the axial piston unit is installed outside of the tank below the minimum hydraulic fluid level.



Recommended installation positions: 1 and 2.

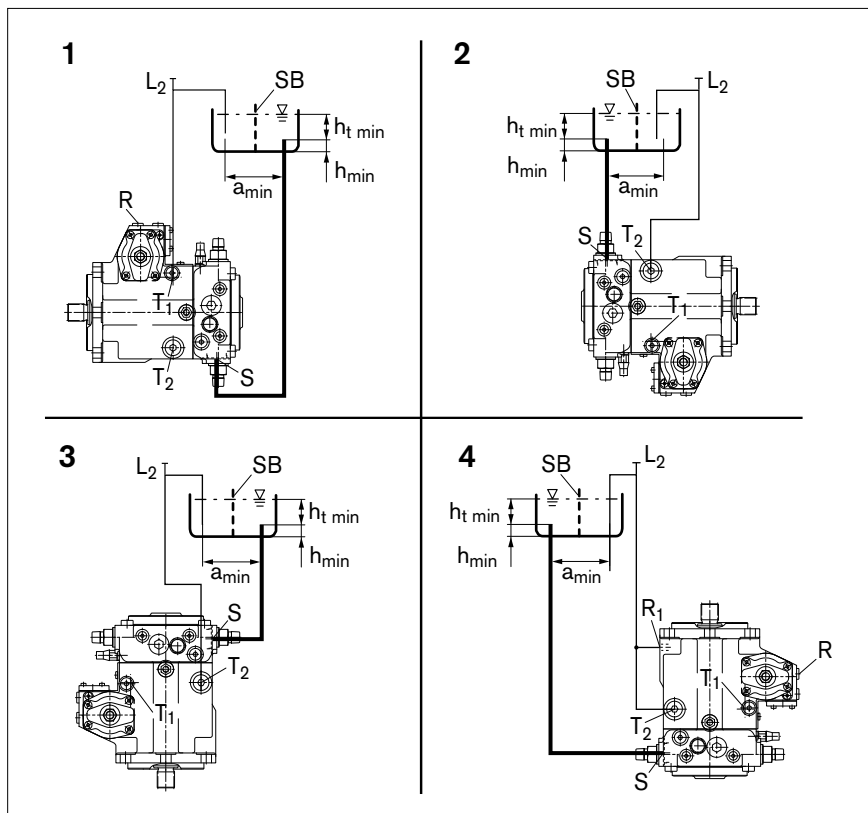

Fig. 18: Below-tank installation with installation positions 1–4

<b>L<sub>2</sub></b>	Filling / air bleeding	<b>SB</b>	Baffle (baffle plate)
<b>R</b>	Air bleed port	<b>h<sub>t min</sub></b>	Min. permissible immersion depth (200 mm)
<b>S</b>	Suction port	<b>h<sub>min</sub></b>	Min. permissible spacing from suction port to tank base (100 mm)
<b>T<sub>1</sub></b>	Case drain port	<b>a<sub>min</sub></b>	Minimum spacing from suction line to return line (200 mm)
<b>T<sub>2</sub></b>	Case drain port		

Table 5: Below-tank installation

Installation position	Air bleeding	Filling
1 (drive shaft, horizontal)	R	S + T <sub>1</sub> (L <sub>2</sub> )
2 (drive shaft, horizontal)	L <sub>2</sub>	S + T <sub>2</sub> (L <sub>2</sub> )
3 (drive shaft, downward)	L <sub>2</sub>	S + T <sub>2</sub> (L <sub>2</sub> )
4 (drive shaft, upward)	R + L <sub>2</sub> (sizes 28–56) <sup>1)</sup> R <sub>1</sub> + L <sub>2</sub> (sizes 71–250)	S + T <sub>2</sub> (L <sub>2</sub> )

<sup>1)</sup> For sizes 28–56, R must be connected instead of R<sub>1</sub>.

### 6.3.2 Above-tank installation

Above-tank installation is when the axial piston unit is installed above the minimum fluid level of the tank.

---

**CAUTION!****Risk of damage to the product!**

An air pocket in the area near the bearings will damage the axial piston unit.

- ▶ Make certain that the pump case is completely filled with hydraulic fluid during commissioning and during operation with the "drive shaft upward" installation position.
  - ▶ Check the hydraulic fluid level in the case interior regularly; if necessary, recommission. With above-tank installation, the case interior may drain via the case drain line after longer standstill periods (air enters via the shaft seal ring) or via the service line (gap leakage). The bearings are thus insufficiently lubricated when the pump is restarted.
  - ▶ Make certain that the suction line is always filled with hydraulic fluid during commissioning and operation.
-

Assembly



Observe the maximum permissible suction height  $h_{Smax} = 800$  mm.

Recommendation for installation position 8 (drive shaft upward): A check valve in the case drain line (opening pressure 0.5 bar) can prevent draining of the case interior.

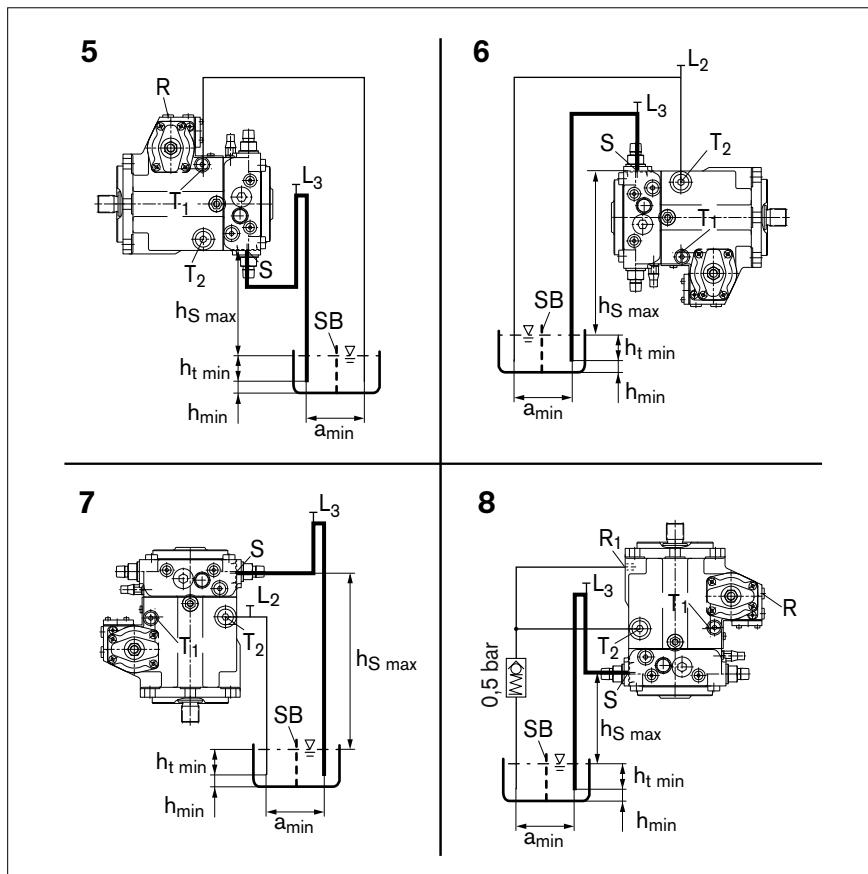

Fig. 19: Above-tank installation with installation positions 5–8

<b>L<sub>2/3</sub></b>	Filling / air bleeding	<b>SB</b>	Baffle (baffle plate)
<b>R</b>	Air bleed port	<b>h<sub>tmin</sub></b>	Min. permissible immersion depth (200 mm)
<b>S</b>	Suction port	<b>h<sub>min</sub></b>	Min. permissible spacing from suction port to tank base (100 mm)
<b>T<sub>1</sub></b>	Case drain port	<b>h<sub>Smax</sub></b>	Maximum permissible suction height (800 mm)
<b>T<sub>2</sub></b>	Case drain port	<b>a<sub>min</sub></b>	Minimum spacing from suction line to return line (200 mm)

Table 6: Above-tank installation

Installation position	Air bleeding	Filling
5 (drive shaft, horizontal)	R	T <sub>1</sub> + S (L <sub>3</sub> )
6 (drive shaft, horizontal)	L <sub>2</sub>	S (L <sub>3</sub> ) + T <sub>2</sub> (L <sub>2</sub> )
7 (drive shaft, downward)	L <sub>2</sub> + L <sub>3</sub>	S (L <sub>3</sub> ) + T <sub>2</sub> (L <sub>2</sub> )
8 (drive shaft, upward)	R + L <sub>3</sub> (sizes 28–56) <sup>1)</sup> R <sub>1</sub> + L <sub>3</sub> (sizes 71–250)	S (L <sub>3</sub> ) + T <sub>2</sub>

1) For sizes 28–56, R must be connected instead of R1.



## 6.4 Assembling the axial piston unit

### DANGER!



#### Systems which are in operation pose a risk of injury!

Working on operating systems poses a danger to life and limb. The work steps described in this chapter must only be performed on systems which are at a standstill. Before beginning work:

- ▶ Ensure that the engine cannot be switched on.
- ▶ Ensure that all power-transmitting components and connections (electric, pneumatic, hydraulic) are switched off according to the manufacturer's instructions and are secured against being switched on again. If possible, remove the main fuse for the system.
- ▶ Ensure that the system is completely hydraulically relieved and depressurized. Please follow the system manufacturer's instructions.
- ▶ Only qualified personnel (see chapter "2.3 Personnel qualifications" on page 6) are authorized to assemble the axial piston unit.

### 6.4.1 Preparation

1. Check the delivery contents for completeness and transport damages.
2. Compare the material number and designation (ordering code) with the details in the order confirmation.



If the material number for the axial piston unit does not correspond to the one in the order confirmation, contact Rexroth Service for clarification, see chapter "9.5 Spare parts" for address.

3. Before assembling, completely empty the axial piston unit to prevent mixing with the hydraulic fluid used in the system.
4. Check the direction of rotation of the axial piston unit (on the name plate) and make sure that this corresponds to the direction of rotation of the engine.

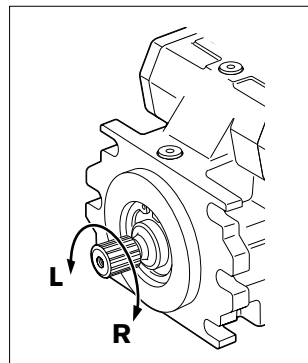

Fig. 20: Direction of rotation

- L Counter-clockwise  
R Clockwise



The direction of rotation as specified on the name plate determines the direction of rotation of the axial piston unit as viewed on the drive shaft. For information on the direction of rotation of the engine, please refer to the engine manufacturer's operating instructions.

### 6.4.2 Dimensions

The installation drawing contains the dimensions for all ports on the axial piston unit. Also observe the instructions provided by the manufacturers of the other components when selecting the required tools.

### 6.4.3 General instructions

During assembly and disassembly of the axial piston unit, observe the following general instructions and handling instructions:

- After a short operating time, toothed belts lose a major portion of their pre-tension and thus cause speed variations and torsional vibrations. Torsional vibrations may cause leakages on the shaft seal ring or increased rotary angle accelerations of the rotary group of the driven axial piston unit. Particularly at risk are diesel drives with a small number of cylinders and low flywheel mass.
- V-belt drives without automatic tensioning device are also critical with regard to speed variations and torsional vibrations. These can also lead to leakages on the shaft seal ring.  
An automatic tensioning device can lessen the speed variations and vibrations and thus avoid consequential damage.
- When driving an axial piston unit with the aid of a cardan shaft, vibrations may occur which result in leakages on the shaft seal ring of the axial piston unit depending on the temperature and frequency.
  - ▶ When driving with toothed belts or v-belts, always use an automatic tensioning device.
  - ▶ Fix the axial piston unit so that the expected forces and torques can be transferred without any danger.
  - ▶ The permissible axial and radial loading of the drive shaft, the permissible torsional vibrations, the optimum direction of load force, as well as the limit speeds can be found in the data sheet.
  - ▶ Observe the permissible radial forces on the drive shaft when driving with radial loading (belt drives). If necessary, the belt disc must be separately mounted.

---

**WARNING!****Risk of damage!**

Hitting or impulsive forces on the drive shaft can damage the axial piston unit.

- ▶ Do not hit the coupling or drive shaft of the axial piston unit.
- ▶ Do not set/place the axial piston unit on the drive shaft.
- ▶ Details on the permissible axial and radial forces can be found in the data sheet.

---

How to assemble the axial piston unit depends on the connecting elements to the drive side. The following descriptions explain the installation of the axial piston unit:

- with a coupling
- on a gearbox

#### 6.4.4 Installation with coupling

How to assemble the axial piston unit with a coupling is described in detail in the following:

1. Assemble the specified coupling half onto the drive shaft of the axial piston unit according to the instructions of the coupling manufacturer.



The drive shaft end of the axial piston unit is provided with a threaded bore. Use this threaded bore to pull the coupling element onto the drive shaft. Refer to the installation drawing for the dimensions of the threaded bore.

2. Make sure that the installation location is clean and free from dirt and contaminants.
3. Clamp the coupling hub onto the drive shaft or ensure permanent lubrication of the drive shaft. This prevents the formation of frictional corrosion and the associated wear.
4. Transport the axial piston unit to the installation location.
5. Assemble the coupling onto the drive according to the instructions of the coupling manufacturer.



The axial piston unit must not be tightened down until the coupling has been correctly assembled.

6. Fix the axial piston unit at the installation location.
7. If necessary, details on the required tools and tightening torques for the fixing screws are available from the machine or system manufacturer.
  - For bell housing installation, check the coupling axial play through the bell window according to the manufacturer's instructions.
  - For flange installation, align the support for the axial piston unit with the drive.
8. When using flexible couplings, check that the drive is free of resonance after completing the installation.

#### 6.4.5 Installation on a gearbox

How to assemble the axial piston unit on a gearbox is described in detail in the following:

After installing on a gearbox, the axial piston unit is covered and is difficult to access:

- ▶ Therefore, before installing, make sure that the centering diameter centers the axial piston unit (observe tolerances) and that no impermissible axial or radial forces act on the drive shaft of the axial piston unit (installation length).
- ▶ Protect the plug connections of the drive shaft from frictional corrosion by providing permanent lubrication.

### 6.4.6 Completing assembly

1. Remove any mounted transport screws.
2. Remove the transport protection.  
The axial piston unit was delivered with protective covers and plastic plugs or locking screws. These must be removed before connecting. Use appropriate tools.
3. Make certain that the sealing and functional surfaces are not damaged.



Ports which are intended for connecting lines are provided with plastic plugs or locking screws, which serve as transport protection. If no connection is made, these ports must be plugged with a suitable metal locking screw since the plastic plugs are not pressure-proof.

**CAUTION!**



**Risk of personal injury or damage to equipment!**

Operating the axial piston unit with plastic plugs can result in injuries or damage to the axial piston unit.

- ▶ Before commissioning, remove all plastic plugs and replace them with suitable, pressure-proof, metal locking screws.

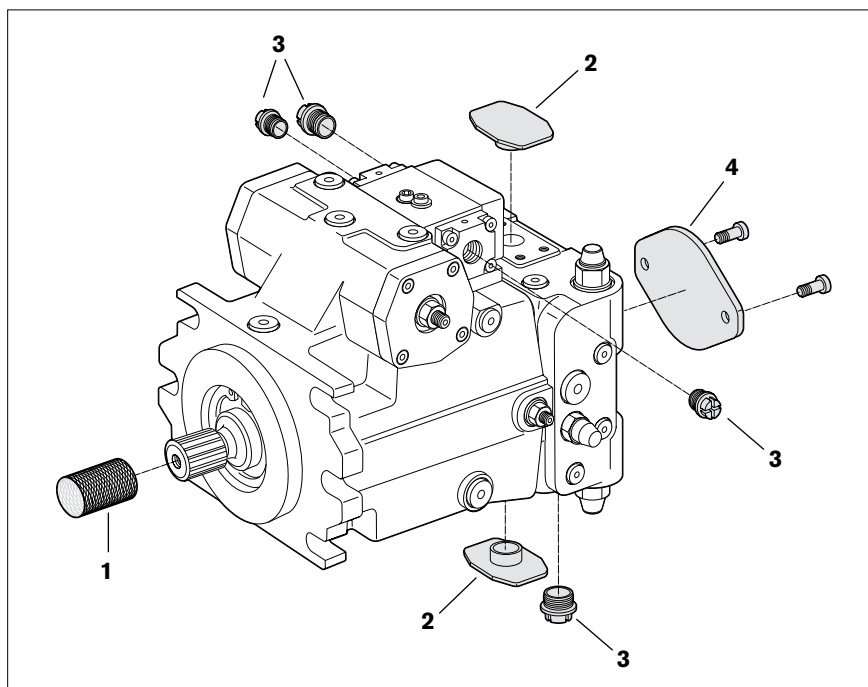

**Fig. 21: Removing transport protection**

- |   |   |
|---|---|
| <ol style="list-style-type: none"> <li>1 Transport protection for shaft end</li> <li>2 Protective covers</li> <li>3 Plastic plugs / locking screws</li> </ol> | <ol style="list-style-type: none"> <li>4 Flange cover and fixing screws (optional for versions with through drive)</li> </ol> |
|---|---|



The adjusting screws are protected against unauthorized resetting by means of protective caps. Removal of the protective caps will void the warranty. If you need a modification of the setting, please contact your responsible Rexroth Service (address as to chapter "9.5 Spare parts").

4. For versions with through drive, assemble the auxiliary pump according to the pump manufacturer's instructions.

#### 6.4.7 Hydraulically connecting the axial piston unit

The machine or system manufacturer is responsible for dimensioning the lines. The axial piston unit must be connected to the rest of the hydraulic system in accordance with the hydraulic circuit diagram of the machine or system manufacturer.

---

#### CAUTION!



#### Damage to the axial piston unit!

When assembling hydraulic lines and hoses under mechanical stress, they are exposed to additional mechanical forces during operation which reduce the service life of the axial piston unit and the entire machine or system.

- ▶ Assemble hydraulic lines and hoses without mechanical stress.
- 

---

#### CAUTION!



#### Risk of damage!

Generally, a minimum permissible suction pressure at port "S" is specified for axial piston pumps in all installation positions. If the pressure at port "S" drops below the specified values, damage may occur which may lead to destruction of the axial piston pump.

- ▶ Make certain that the necessary suction pressure is achieved. This is influenced by:
    - appropriate piping of the suction cross-section
    - appropriate pipe diameters
    - appropriate position of the tank
    - appropriate viscosity of the hydraulic fluid
    - filter cartridge in the suction line (regularly check the level of soiling of the filter cartridge)
- 



Only connect hydraulic lines to the service and function ports.

---

#### CAUTION!



#### Wear and malfunctions!

The cleanliness of the hydraulic fluid has a considerable impact on the cleanliness and service life of the hydraulic system. Any contamination of the hydraulic fluid leads to wear and malfunctions. In particular, contaminants like e.g. welding beads or metal cuttings in the hydraulic lines may damage the axial piston unit.

- ▶ Absolute cleanliness is required.
  - ▶ The axial piston unit must be installed in a clean condition.
  - ▶ Make sure that all ports, hydraulic lines and add-on units (e.g. testers) are clean.
  - ▶ Make sure that no contaminants may penetrate when sealing the ports.
  - ▶ Take care that no detergents enter the hydraulic system.
  - ▶ Do not use any cotton waste or linty cloths for cleaning.
  - ▶ Do not use hemp as sealant under any circumstances.
-

## Assembly

### Notes on routing the lines

Observe the following notes when routing the suction, pressure and case drain lines.

- ▶ Make certain that the suction line (pipe or hose) is as short and straight as possible.
- ▶ The line cross section of the suction line is to be measured so that the minimum permissible pressure at the suction port is not dropped below and the maximum permissible pressure is not exceeded.
- ▶ Observe the air tightness of the junctions and the pressure resistance of the hose, also with respect to the external air pressure.
- ▶ With the pressure lines, make certain that the pipes, hoses and connecting elements are approved for the operating pressure range.
- ▶ Always route the case drain lines so that the housing is constantly filled with hydraulic fluid and to ensure that no air gets through the shaft seal ring even during extended standstill periods. The case internal pressure must not exceed the limit values listed for the axial piston unit in the data sheet under any operating conditions. The case drain line in the tank must end up below the minimum fluid level under all conditions (see chapter "6.3 Installation position").



The ports and fixing threads are designed for the operating pressures specified in the data sheet. The machine or system manufacturer must ensure that the connecting elements and lines correspond to the specified operating conditions (pressure, flow, hydraulic fluid, temperature) with the necessary safety factors.

### Procedure

To connect the axial piston unit to the hydraulic system:

1. Remove the locking screws at the ports at which the connections are to be made according to the hydraulic circuit diagram.
2. Use only clean hydraulic lines.
3. Connect the lines according to the hydraulic circuit diagram. Either pipes or hoses must be connected to all ports according to the installation drawing and machine or system circuit diagram or the ports plugged using suitable locking screws.



The installation drawing contains the dimensions for all connections and ports on the axial piston unit. Also observe the instructions provided by the manufacturers of the other hydraulic components when selecting the required tools.

4. Make sure
  - that the cap nuts are correctly tightened on the fittings and flanges (observe tightening torques!). Mark all checked fittings using e.g. a permanent marker.
  - that the pipes and hose lines and every combination of connecting piece, coupling or connecting point with hoses or pipes have been inspected by a technically qualified person for safe working condition.

Port overview

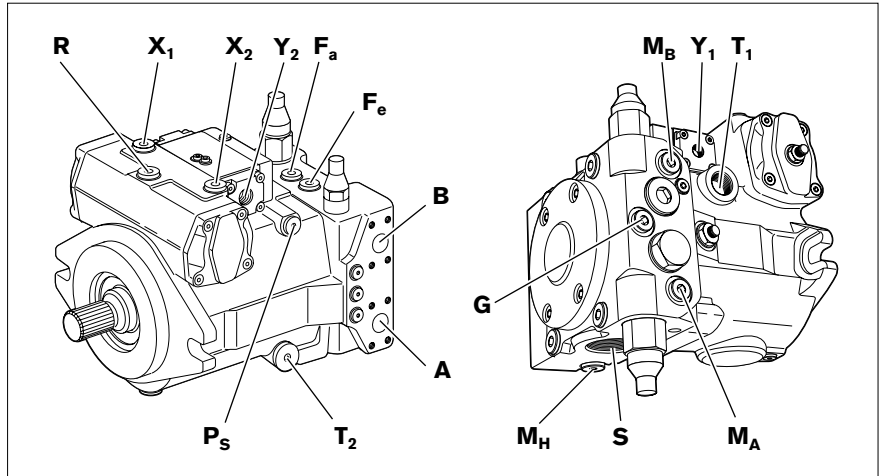

Fig. 22: Port overview, size 28

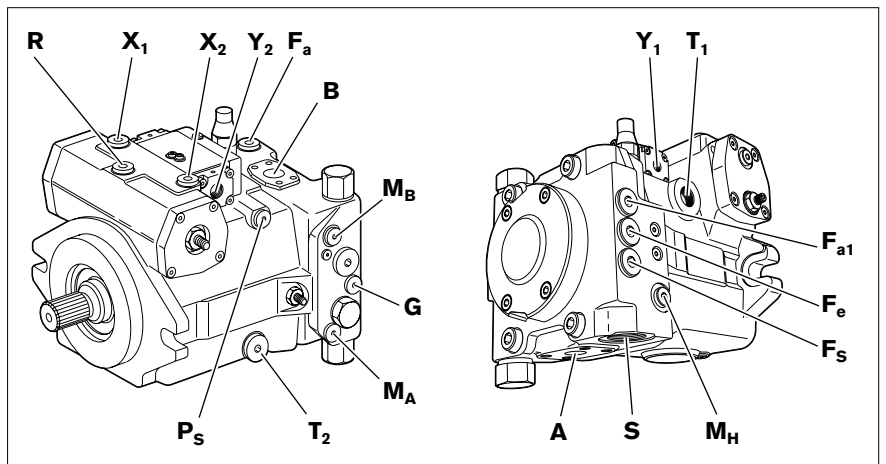

Fig. 23: Port overview, sizes 40/56

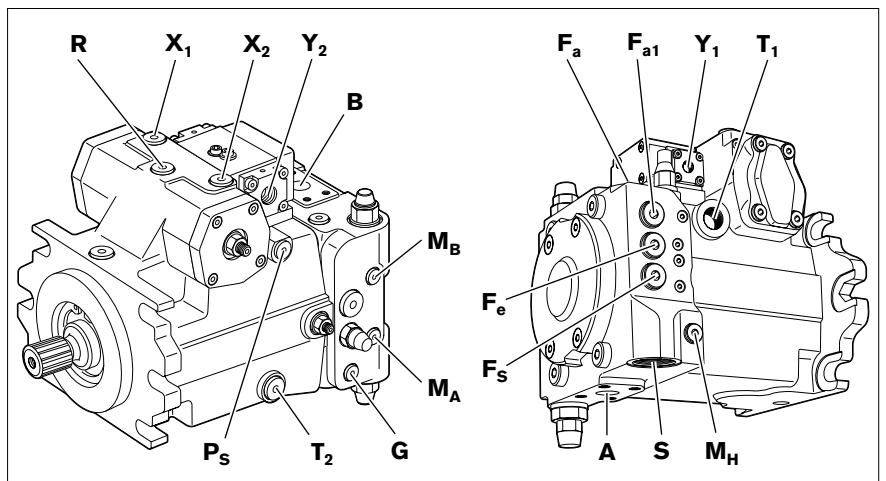

Fig. 24: Port overview, sizes 71 to 180

## Assembly

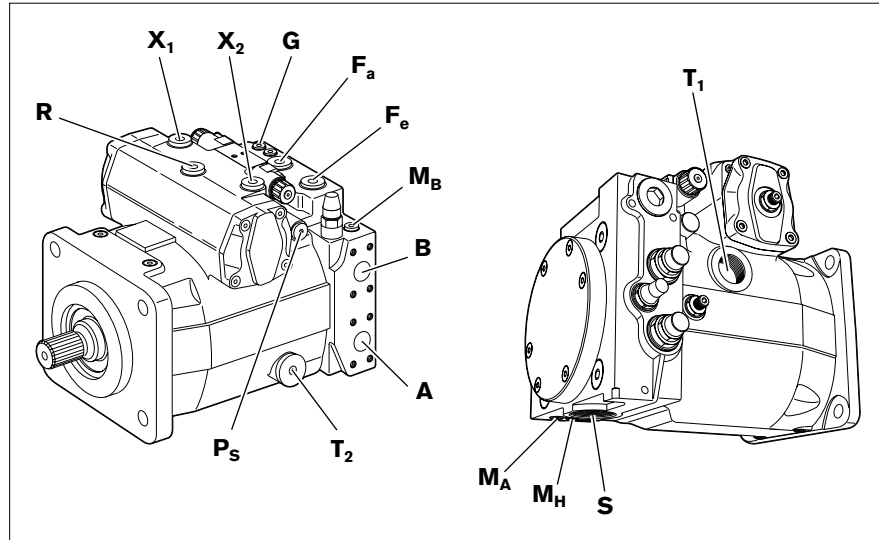

Fig. 25: Port overview, size 250

Table 7: Ports for A4VG series 32

Designation	Port for	Standard	Peak pressure (bar) <sup>1)</sup>	State
<b>A, B</b>	Service line Fixing threads	SAE J518 <sup>2)</sup> DIN 13	450	O
<b>S</b>	Suction	DIN 3852	5	O <sup>3)</sup>
<b>T<sub>1</sub></b>	Tank	DIN 3852	3	O <sup>4)</sup>
<b>T<sub>2</sub></b>	Tank	DIN 3852	3	X <sup>4)</sup>
<b>R</b>	Air bleed	DIN 3852	3	X
<b>X<sub>1</sub>, X<sub>2</sub></b>	Control pressure (upstream the throttle)	DIN 3852	40	X
<b>G</b>	Boost pressure	DIN 3852	40	X
<b>P<sub>s</sub></b>	Pilot pressure inlet	DIN 3852	40	X
<b>M<sub>A</sub>, M<sub>B</sub></b>	Measuring pressure A, B	DIN 3852	450	X
<b>M<sub>H</sub></b>	Measuring high pressure	DIN 3852	450	X
<b>F<sub>a</sub></b>	Boost pressure inlet	DIN 3852	40	X <sup>6)</sup>
<b>F<sub>a1</sub></b>	Boost pressure, inlet (mountable filter)	DIN 3852	40	X
<b>F<sub>e</sub> <sup>5)</sup></b>	Boost pressure outlet	DIN 3852	40	X <sup>6)</sup>
<b>F<sub>s</sub></b>	Connection of filter to suction line (cold start)	DIN 3852	5	X
<b>Y<sub>1</sub>, Y<sub>2</sub></b>	Control signal (HD only)	DIN 3852	18	O
<b>Z</b>	Inching signal (DA4/8 only)	DIN 3852	70	O
<b>Y</b>	Pilot pressure port (DA7 only)	DIN 3852	40	O

<sup>1)</sup> Brief pressure spikes may occur depending on the application. Keep this in mind when selecting testers and armatures.

<sup>2)</sup> Only dimensions according to SAE J518

<sup>3)</sup> Plugged for external supply

<sup>4)</sup> Depending on installation position, either T<sub>1</sub> or T<sub>2</sub> must be connected (see also chapter "6.3 Installation position")

<sup>5)</sup> Optional

<sup>6)</sup> Must be connected for filtration in the pressure line

O = Must be connected (plugged with plastic plugs on delivery)

X = Plugged (in normal operation)



**Tightening torques** The following tightening torques apply:

- Threaded hole in the axial piston unit: The maximum permissible tightening torques  $M_{Gmax}$  are the maximum values of the threaded holes and must not be exceeded. For values, refer to the following table.
- Armatures:  
Observe the manufacturer's instruction regarding tightening torques for the used armatures.
- Fixing screws:  
For fixing screws according to DIN 13/ISO 68, we recommend checking the tightening torque in individual cases as per VDI 2230.
- Locking screws:  
For the metal locking screws supplied with the axial piston unit, the required tightening torques of locking screws  $M_V$  apply. For values, refer to the following table.

**Table 8: Tightening torques of the threaded holes and locking screws**

Threaded size of the ports		Max. permissible tightening torque of the threaded holes $M_{Gmax}$	Required tightening torque of the locking screws $M_V$	WAF hexagon socket
M10x1	DIN 3852	30 Nm	12 Nm	5 mm
M12x1.5	DIN 3852	50 Nm	25 Nm	6 mm
M14x1.5	DIN 3852	80 Nm	35 Nm	6 mm
M16x1.5	DIN 3852	100 Nm	50 Nm	8 mm
M18x1.5	DIN 3852	140 Nm	60 Nm	8 mm
M22x1.5	DIN 3852	210 Nm	80 Nm	10 mm
M26x1.5	DIN 3852	230 Nm	120 Nm	12 mm
M27x2	DIN 3852	330 Nm	135 Nm	12 mm
M33x2	DIN 3852	540 Nm	225 Nm	17 mm
M42x2	DIN 3852	720 Nm	360 Nm	22 mm
M48x2	DIN 3852	900 Nm	400 Nm	24 mm
5/16-24 UNF-2B	ISO 11926	10 Nm	7 Nm	1/8 in
3/8-24 UNF-2B	ISO 11926	20 Nm	7 Nm	5/32 in
7/16-20 UNF-2B	ISO 11926	40 Nm	15 Nm	3/16 in
9/16-18 UNF-2B	ISO 11926	80 Nm	25 Nm	1/4 in
3/4-16 UNF-2B	ISO 11926	160 Nm	62 Nm	5/16 in
7/8-14 UNF-2B	ISO 11926	240 Nm	127 Nm	3/8 in
1 1/16-12 UN-2B	ISO 11926	360 Nm	147 Nm	9/16 in
1 5/16-12 UN-2B	ISO 11926	540 Nm	198 Nm	5/8 in
1 5/8-12 UN-2B	ISO 11926	960 Nm	320 Nm	3/4 in
1 7/8-12 UN-2B	ISO 11926	1200 Nm	390 Nm	3/4 in

## Assembly

**Risk of mix-ups with threaded connections**

The axial piston units are used in application areas with metric as well as with Imperial systems of units.

Both the system of units as well as the size of threaded hole and threaded plug (e.g. locking screw) must match.

Due to the lack of options for visually detecting differences, there is a risk of mix-ups.

**WARNING!****Risk of damage to persons and property!**

If a threaded plug which is of a different measurement system and size with respect to the threaded hole is pressurized, the threaded plug may loosen itself or even be ejected from the hole in a projectile-like manner.

This can result in serious injury and damage to equipment. Hydraulic fluid can be discharged from this leakage point.

- ▶ Use the drawings (installation drawing/data sheet) to determine the required threaded plug for each fitting.
- ▶ Make certain that there are no mix-ups when assembling armatures, fixing screws and locking screws.
- ▶ For all threaded holes, use a threaded plug from the same system of units and of the correct size.

**6.4.8 Electrical connection of the axial piston unit**

The machine or system manufacturer is responsible for the layout of the electric control.

For electrically controlled axial piston units, the electric control must be connected according to the circuit diagram of the system manufacturer.

**CAUTION!****Short circuit in event of penetrating hydraulic fluid!**

Fluid can penetrate the product and cause a short circuit.

- ▶ Do not install electrically controlled axial piston units in a tank below the tank fluid level (tank installation).

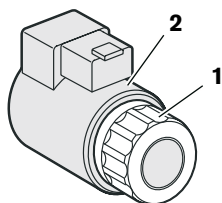
**Changing plug position**

1. Switch off power supply to the relevant system component.

2. Electrically connect the axial piston unit (12 or 24 V).

If necessary, you can change the position of the plug by turning the solenoid.

To do this, proceed as follows:

1. Loosen the fixing nut (1) of the solenoid. To do this, turn the fixing nut (1) one turn counter-clockwise.
2. Turn the solenoid body (2) to the desired position.
3. Retighten the fixing nut. Tightening torque of the fixing nut: 5+1 Nm.

For further details and technical data, e.g. regarding the selection of a suitable mating connector, please refer to data sheet RE 92003.

## 7 Commissioning

**WARNING!****Danger while working in the danger zone of a machine or system!**

It is not permissible to work in the danger zone of a machine or system.

- ▶ The machine or system must only be operated if safe working is ensured.
- ▶ Pay attention to and rectify potential danger sources before operating the machine or system.
- ▶ Nobody may stand in the danger zone of the machine or system.
- ▶ The emergency stop button for the machine or system must be within the operator's reach.
- ▶ Always follow the instructions of the machine or system manufacturer during commissioning.

**CAUTION!****Risk of damage to persons and property!**

Commissioning of the axial piston unit requires basic mechanical and hydraulic knowledge.

- ▶ Only qualified personnel (see chapter "2.3 Personnel qualifications" on page 6) are authorized to commission the axial piston unit.

**WARNING!****Risk of toxication and injury!**

Contact with hydraulic fluids may damage your health (e.g. eye injuries, skin damage, toxication upon inhalation).

- ▶ Always check the lines for wear and damage before each commissioning.
- ▶ While performing these checks, wear safety gloves, safety glasses and suitable working clothes.
- ▶ If hydraulic fluid should, nevertheless, come into contact with your eyes or penetrate your skin, consult a doctor immediately.
- ▶ When working with hydraulic fluids, strictly observe the safety instructions provided by the hydraulic fluid manufacturer.

**WARNING!****Fire hazard!**

Hydraulic fluid is easily flammable.

- ▶ Keep open flames and ignition sources from the axial piston unit.

**CAUTION!****Missing seals and connections lead to noncompliance with the protection class!**

Fluids and contaminants may penetrate and damage the product.

- ▶ Prior to assembly, make sure that all seals and connectors are tight.

## Commissioning

## 7.1 First commissioning

**CAUTION!**

**Risk of damage to the product!**

Any contamination of the hydraulic fluid leads to wear and malfunctions. In particular, contaminants like e.g. welding beads or metal cuttings in the hydraulic lines may damage the axial piston unit.

- ▶ Ensure utmost cleanliness during commissioning.
- ▶ Make sure that no contaminants may penetrate when sealing the gauge ports.

**CAUTION!**

**Risk of damage to the product!**

If you commission the axial piston unit without or with insufficient hydraulic fluid, the axial piston unit is damaged immediately or even destroyed.

- ▶ When commissioning or recommissioning a machine or system, make sure that the case interior and the suction and service lines of the axial piston unit are filled with hydraulic fluid and remain filled during operation.



When commissioning the axial piston unit, observe the basic safety instructions and intended use provided in chapter "2 General safety instructions".

### 7.1.1 Filling the axial piston unit

You will require an approved hydraulic fluid:

The machine or system manufacturer can provide you with precise details on the hydraulic fluid. Details on minimum requirements for mineral-oil based hydraulic fluids, environmentally acceptable hydraulic fluids or HF hydraulic fluids for the axial piston unit are available in the Rexroth publications RE 90220, RE 90221 and RE 90223, respectively.

To ensure the functional reliability of the axial piston unit, cleanliness level 20/18/15 according to at least ISO 4406 is necessary for the hydraulic fluid. At very high hydraulic fluid temperatures (+90 °C to maximum +115 °C), cleanliness level 19/17/14 according to at least ISO 4406 is necessary. For permissible temperatures, see the data sheet.

**CAUTION!**

**Risk of damage to the product!**

An air pocket in the area near the bearings will damage the axial piston unit.

- ▶ Make certain that the pump case is completely filled with hydraulic fluid during commissioning and during operation with the "drive shaft upward" installation position.
- ▶ Check the hydraulic fluid level in the case interior regularly; if necessary, recommission. With above-tank installation, the case interior may drain via the case drain line after longer standstill periods (air enters via the shaft seal ring) or via the service line (gap leakage). The bearings are thus insufficiently lubricated when the pump is restarted.
- ▶ Make certain that the suction line is always filled with hydraulic fluid during commissioning and operation.



The axial piston unit should be filled with a filling unit (10  $\mu\text{m}$  filter grade). The axial piston unit must not be operated while it is being filled.

---

**CAUTION!**

**Danger of environmental contamination!**

The discharge or spillage of hydraulic fluid while filling the axial piston unit can lead to environmental pollution and contamination of the groundwater.

- ▶ When filling and changing the hydraulic fluid, always place a catch pan under the axial piston unit.
  - ▶ Observe the information in the safety data sheet for the hydraulic fluid and the specifications provided by the system manufacturer.
- 

1. Fill and air bleed the axial piston unit via the appropriate ports, see chapter "6.3 Installation position". The hydraulic lines of the system must also be filled.
2. Test the direction of rotation of the engine. To do this, rotate the engine briefly at the lowest rotational speed (inching). Make sure that direction of rotation of the axial piston unit matches the details on the name plate, see also chapter "4.4 Product identification", Fig. 14: Name plate.
3. Operate the axial piston pump at a lower speed (starter speed for internal combustion engines or inching operation for electric motors) until the pump system is completely filled and bled. To inspect, drain the hydraulic fluid at the case drain port and wait until it drains without bubbles.
4. Make certain that all ports are either connected to pipes or plugged according to the general circuit diagram.

### 7.1.2 Testing the hydraulic fluid supply

The axial piston unit must always have a sufficient supply of hydraulic fluid. For this reason, the supply of hydraulic fluid must be ensured at the start of the commissioning process.

When you test the hydraulic fluid supply, constantly monitor the noise development and check the hydraulic fluid level in the tank. If the axial piston unit becomes louder (cavitation) or the case drain fluid is discharged with bubbles, this is an indication that the axial piston unit is not being sufficiently supplied with hydraulic fluid.

Notes on troubleshooting can be found in chapter "14 Troubleshooting".

To test the hydraulic fluid supply:

1. Allow the engine to run at the slowest speed. The axial piston unit must be operated without load. Pay attention to leakage and noise.
2. Check the axial piston unit's case drain line during the test. The case drain fluid should not contain any bubbles.
3. Check the suction pressure at port "S" of the axial piston pump. Refer to data sheet RE 92003 for the permissible value.
4. Check the case drain pressure at connected port "T<sub>1</sub>" or "T<sub>2</sub>". Refer to data sheet RE 92003 for the permissible value.

## Commissioning

### 7.1.3 Performing functional test

**WARNING!****Risk of injury in case of incorrectly connected machine or system!**

Any change of the connections will lead to malfunctions (e.g. lift instead of lower) and thus represents a corresponding danger to persons and equipment.

- ▶ When connecting hydraulic components, observe the specified piping according to the hydraulic circuit diagram of the machine or system manufacturer.

Once you have tested the hydraulic fluid supply, you must perform a functional test on the machine or system. The functional test should be performed according to the instructions of the machine or system manufacturer.

The axial piston unit is checked for functional capability before delivery according to the technical data. During commissioning, it must be ensured that the axial piston unit was installed in accordance with the design of the machine or system.

### 7.1.4 Performing flushing cycle

In order to remove foreign bodies from the system, Rexroth recommends a flushing cycle for the entire system.



During the flushing cycle, the axial piston unit must be operated without load. The flushing cycle can be performed, e.g. by using an additional flushing unit. Follow the instructions of the flushing unit's manufacturer for the exact procedure during the flushing cycle.

## 7.2 Recommissioning after downtime

Depending on the installation conditions and ambient conditions, changes may occur in the system which make recommissioning necessary.

Among others, the following criteria may make recommissioning necessary:

- Air in the hydraulic system
  - Water in the hydraulic system
  - Old hydraulic fluid
  - Other contamination
- ▶ Before recommissioning, proceed as described in chapter "7.1 First commissioning".

## 7.3 Running-in phase

The bearings and sliding surfaces are subject to a running-in phase. The increased friction at the start of the running-in phase results in increased heat development which decreases with increasing operating hours. The volumetric and mechanical-hydraulic efficiency increases as well through the conclusion of the running-in phase of approx. 10 operating hours.

**CAUTION!****Risk of damage by insufficient viscosity!**

The increased temperature of the hydraulic fluid during the running-in phase can cause the viscosity to drop to impermissible levels.

- ▶ Monitor the operating temperature during the running-in phase.
- ▶ Reduce the loading (pressure, rpm) of the axial piston unit if impermissible operating temperatures and/or viscosities occur.

## 8 Operation

The product is a component which requires no settings or changes during operation. For this reason, this chapter of the manual does not contain any information on adjustment options. Only use the product within the performance range provided in the technical data. The machine or system manufacturer is responsible for the proper project planning of the hydraulic system and its control.

## 9 Maintenance and repair

### 9.1 Cleaning and care

**CAUTION!**

**Damage to the surface caused by solvents and aggressive detergents!**

Aggressive detergents may damage the seals on the axial piston unit and cause them to age faster.

- ▶ Never use solvents or aggressive detergents.

**CAUTION!**

**Damage to the hydraulic system and the seals!**

A high-pressure cleaner's water pressure could damage the electronics and the seals of the axial piston unit.

- ▶ Do not point a high-pressure cleaner at sensitive components such as, e.g. shaft seal ring, electrical connections and electrical components.

For cleaning and care of the axial piston unit, observe the following:

- ▶ Plug all openings with suitable protective caps/devices.
- ▶ Check whether all seals and plugs of the plug connections are securely seated to ensure that no moisture can penetrate into the axial piston unit during cleaning.
- ▶ Use only water and, if necessary, a mild detergent to clean the axial piston unit.
- ▶ Remove coarse dirt from the outside of the machine and keep sensitive and important components, such as solenoids, valves and displays, clean.

### 9.2 Inspection

In order to enable long and reliable operation of the axial piston unit, Rexroth recommends testing the hydraulic system and axial piston unit on a regular basis and to document the following operating conditions:

**Table 9: Inspection schedule**

Task to be carried out		Interval
Hydraulic system	Check level of hydraulic fluid in the tank.	daily
	Check operating temperature (comparable load state).	weekly
	Check quality of the hydraulic fluid.	yearly or every 2000 h (which ever occurs first)
Axial piston unit	Check axial piston unit for leakage. Early detection of hydraulic fluid loss can help to find faults on the machine or system and to rectify them. For this reason, Rexroth recommends that the axial piston unit and system always be kept in a clean condition.	daily
	Check axial piston unit for noise development.	daily
	Check fixing elements for tight seating. All fixing elements have to be checked when the system is switched off, depressurized and cooled down.	monthly



### 9.3 Maintenance

The axial piston unit is low maintenance when used as intended.

The service life of the axial piston unit is heavily dependent on the quality of the hydraulic fluid. For this reason, we recommend changing the hydraulic fluid at least once per year or every 2000 operating hours (whichever occurs first) or having it analyzed by the hydraulic fluid manufacturer or a laboratory to determine its suitability for further use.

The service life of the axial piston unit is limited by the service life of the built-in bearings. The service life can be requested from the responsible Rexroth Service partner, see "9.5 Spare parts" for address. Based on these details, a maintenance period is to be determined by the system manufacturer for the replacement of the bearings and included in the maintenance schedule of the hydraulic system.

### 9.4 Repair

Rexroth offers a comprehensive range of services for the repair of Rexroth axial piston units.

Repairs of the axial piston unit may only be performed by authorized, skilled and instructed personnel.

- ▶ Only use genuine spare parts from Rexroth for repairing the Rexroth axial piston units.

Tested and pre-assembled original Rexroth assembly groups allow for successful repair requiring only little time.

### 9.5 Spare parts

---

**CAUTION!****Damage to persons and property due to faulty spare parts!**

Spare parts that do not meet the technical requirements specified by Rexroth may cause damage to persons or property.

- ▶ Use only original spare parts from Rexroth.

---

The list of spare parts for axial piston units are order specific. When ordering spare parts, please quote the material and serial number of the axial piston unit as well as the material numbers of the spare parts.

Please address all questions regarding spare parts to your responsible Rexroth Service partner or the service department of the manufacture's plant for the axial piston unit.

Bosch Rexroth AG  
Hydraulics  
Product Unit Axial Piston Units  
Elchingen Plant  
GlockeraustraÙe 2  
89275 Elchingen, Germany  
Phone +49 (0) 73 08 82-0  
Fax +49 (0) 73 08 72 74  
service.elchingen@boschrexroth.de

For the addresses of foreign subsidiaries, please refer to  
[www.boschrexroth.com/addresses](http://www.boschrexroth.com/addresses)

## 10 Decommissioning

The axial piston unit is a component that does not require decommissioning. For this reason, this chapter of the manual does not contain any information. For details about how to disassemble or replace your axial piston unit, please refer to chapter "11 Disassembly and replacement".

## 11 Disassembly and replacement

### 11.1 Required tools

Disassembly can be performed with standard tools. No special tools are necessary.

### 11.2 Preparing for disassembly

---

**WARNING!****Risk of injuries due to disassembling under pressure and voltage!**

If you do not switch off pressure and power supply before disassembling the product, you may get injured or the device or system components may be damaged.

- ▶ Make sure that the relevant system components are not under pressure or voltage.

- 
1. Decommission the entire system as described in the overall manual for the machine or system.
  2. Relieve the hydraulic system according to the instructions of the machine or system manufacturer.

### 11.3 Disassembling the axial piston unit

Proceed as follows to disassemble the axial piston unit:

1. Make sure that the hydraulic system is depressurized.
2. Check whether the axial piston unit has cooled down far enough so that it can be disassembled without danger.
3. Place a catch pan under the axial piston unit to collect any hydraulic fluid that may escape.

---

**CAUTION!****Danger of environmental contamination!**

The discharge or spillage of hydraulic fluid while filling the axial piston unit can lead to environmental pollution and contamination of the groundwater.

- ▶ When filling and changing the hydraulic fluid, always place a catch pan under the axial piston unit.
  - ▶ Observe the information in the safety data sheet for the hydraulic fluid and the specifications provided by the system manufacturer.
-

4. Loosen the lines and collect the escaping hydraulic fluid in the collector.
5. Remove the axial piston unit. Use an appropriate lifting device.
6. Completely empty the axial piston unit.
7. Plug all openings.

#### **11.4 Preparing the components for storage or further use**

- ▶ Proceed as described in section "5.2 Storing the axial piston unit".

## 12 Disposal

Observe the following points when disposing of the axial piston unit:

1. Completely empty the axial piston unit.
2. Dispose of the hydraulic fluid according to the national regulations of your country.
3. Disassemble the axial piston unit into its individual parts and properly recycle these parts.
4. Separate parts by:
  - Cast parts
  - Steel
  - Nonferrous metal
  - Electronic waste
  - Plastic
  - Seals.

### 12.1 Environmental protection

Careless disposal of the axial piston unit, the hydraulic fluid and the packaging material could lead to pollution of the environment.

- ▶ Therefore, dispose of the axial piston unit, the hydraulic fluid and the packaging material in accordance with the currently applicable regulations in your country.
- ▶ Dispose of hydraulic fluid residues according to the applicable safety data sheets for these hydraulic fluids.

## 13 Extension and conversion

The axial piston unit must not be converted. This also includes a modification of the adjusting screws.



The warranty from Rexroth only applies to the delivered configuration. In case of extensions or conversions, the warranty will become void.



Adjusting screws are protected against unauthorized resetting by means of protective caps. Removal of the protective caps will void the warranty. If you need a modification of the setting, please contact your responsible Rexroth Service (for address, see chapter "9.5 Spare parts").

## 14 Troubleshooting

The following table may assist you in troubleshooting. The table makes no claim for completeness.

In practical use, problems which are not listed here may also occur.

### 14.1 How to proceed for troubleshooting

- ▶ Always act systematically and targeted, even under pressure of time. Random and imprudent disassembly and readjustment of settings might result in the inability to ascertain the original error cause.
- ▶ First obtain a general overview of how your product works in conjunction with the entire system.
- ▶ Try to find out whether the product has worked properly in conjunction with the entire system before the troubles occurred first.
- ▶ Try to determine any changes of the entire system in which the product is integrated.
  - Were there any changes to the product's operating conditions or operating range?
  - Were there any changes or repair works on the complete system (machine / system, electrics, control) or on the product? If yes, which?
  - Was the product or machine used as intended?
  - How did the malfunction appear?
- ▶ Try to get a clear idea of the error cause. Directly ask the (machine) operator.
- ▶ If you cannot rectify the error, contact one of the contact addresses which can be found under:  
[www.boschrexroth.com/addresses](http://www.boschrexroth.com/addresses).

## Troubleshooting

## 14.2 Malfunction table

Table 10: Malfunction table for variable pumps

Fault	Possible cause	Remedy
Unusual noises	Drive speed too high.	Machine or system manufacturer.
	Wrong direction of rotation.	Ensure correct direction of rotation.
	Insufficient suction conditions, e.g. air in the suction line, insufficient diameter of the suction line, viscosity of the hydraulic fluid too high, suction height too high, suction pressure too low, contaminants in the suction line.	Machine or system manufacturer (e.g. optimize inlet conditions, use suitable hydraulic fluid).
		Completely air bleed axial piston unit, fill suction line with hydraulic fluid.
		Remove contaminants from the suction line.
	Improper fixing of the axial piston unit.	Check fixing of the axial piston unit according to the specifications of the machine or system manufacturer. Observe tightening torques.
	Improper fixing of the attachment parts, e.g. coupling and hydraulic lines.	Fix attachment parts according to the information provided by the coupling or armature manufacturer.
	Pressure-relief valve of the axial piston unit (boost pressure, high pressure, pressure cut-off).	Air bleed axial piston unit Check viscosity of the hydraulic fluid Contact Rexroth Service.
Mechanical damage to the axial piston unit.	Exchange axial piston unit, contact Rexroth Service.	
No or insufficient flow	Faulty mechanical drive (e.g. defective coupling).	Machine or system manufacturer.
	Drive speed too low.	Machine or system manufacturer.
	Insufficient suction conditions, e.g. air in the suction line, insufficient diameter of the suction line, viscosity of the hydraulic fluid too high, suction height too high, suction pressure too low, contaminants in the suction line.	Machine or system manufacturer (e.g. optimize inlet conditions, use suitable hydraulic fluid).
		Completely air bleed axial piston unit, fill suction line with hydraulic fluid.
		Remove contaminants from the suction line.
	Hydraulic fluid not in optimum viscosity range.	Use suitable hydraulic fluid (machine or system manufacturer).
	External control of the control device defective.	Check external control (machine or system manufacturer).
	Insufficient pilot pressure.	Check pilot pressure, contact Rexroth Service.
	Malfunction of the control device or controller of the axial piston unit.	Contact Rexroth Service.
Wear of axial piston unit.	Exchange axial piston unit, contact Rexroth Service.	
Mechanical damage to the axial piston unit.	Exchange axial piston unit, contact Rexroth Service.	

Table 10: Malfunction table for variable pumps

Fault	Possible cause	Remedy
No or insufficient pressure	Faulty mechanical drive (e.g. defective coupling).	Machine or system manufacturer.
	Drive power too low.	Machine or system manufacturer.
	Insufficient suction conditions, e.g. air in the suction line, insufficient diameter of the suction line, viscosity of the hydraulic fluid too high, suction height too high, suction pressure too low, contaminants in the suction line.	Machine or system manufacturer (e.g. optimize inlet conditions, use suitable hydraulic fluid).
		Completely air bleed axial piston unit, fill suction line with hydraulic fluid.
		Remove contaminants from the suction line.
	Hydraulic fluid not in optimum viscosity range.	Use suitable hydraulic fluid (machine or system manufacturer).
	External control of the control device defective.	Check external control (machine or system manufacturer).
	Insufficient pilot pressure.	Check pilot pressure, contact Rexroth Service.
	Malfunction of the control device or controller of the axial piston unit.	Contact Rexroth Service.
	Wear of axial piston unit.	Exchange axial piston unit, contact Rexroth Service.
	Mechanical damage to the axial piston unit.	Exchange axial piston unit, contact Rexroth Service.
Output unit defective (e.g. hydraulic motor or cylinder).	Machine or system manufacturer.	
Pressure/flow fluctuations	Axial piston unit not or insufficiently air bled.	Completely air bleed axial piston unit.
	Insufficient suction conditions, e.g. air in the suction line, insufficient diameter of the suction line, viscosity of the hydraulic fluid too high, suction height too high, suction pressure too low, contaminants in the suction line.	Machine or system manufacturer (e.g. optimize inlet conditions, use suitable hydraulic fluid).
		Completely air bleed axial piston unit, fill suction line with hydraulic fluid.
	Remove contaminants from the suction line.	
Hydraulic fluid temperature too high	Excessive inlet temperature at the axial piston unit.	Machine or system manufacturer: inspect system, e.g. malfunction of the cooler, insufficient hydraulic fluid in the tank.
	Malfunction of the pressure control valves (e.g. high-pressure relief valve, pressure cut-off, pressure controller).	Contact Rexroth Service.
	Malfunction of the flushing valve.	Contact Rexroth Service.
	Wear of axial piston unit.	Exchange axial piston unit, contact Rexroth Service.

## 15 Technical data

The technical data of your axial piston unit can be found in data sheet "RE 92003".

The data sheet can be found on the Internet under [www.boschrexroth.com/axial-piston-pumps](http://www.boschrexroth.com/axial-piston-pumps)

The preset technical data of your axial piston unit can be found in the order confirmation.

## 16 Appendix

### 16.1 Address directory

For the addresses of foreign subsidiaries, please refer to [www.boschrexroth.com/addresses](http://www.boschrexroth.com/addresses)



## 17 Index

### A

- Abbreviations 5
- Above-tank installation 31
- Address directory 56
- Air bleeding 30, 32
- Assembly 11, 27
  - Completing 36
  - General instructions 34
  - On a gearbox 35
  - Preparation 33
  - With coupling 35
- Auxiliary pump 11
- Axial piston unit
  - Assembling 33
  - Conversion 52
  - Dimensions 34
  - Disassembly 50
  - Filling 44
  - Installation conditions 27
  - Installation position 29
  - Maintaining 49
  - Maintenance 48
  - Repair 49
  - Replacing 50
  - Spare parts 49
  - Storing 25
  - Transporting 24
  - Unpacking 27
  - Weight 24

### B

- Below-tank installation 30
- Bypass function
  - Activating the bypass function 19, 20, 22
  - Deactivating the bypass function 20, 21, 22
  - Towing distance 19, 21, 22
  - Towing speed 19, 21, 22

### C

- Care 48
- Caution 7
- Changing solenoid position 42
- Cleaning 48
- Commissioning 43
  - First 44
- Connecting
  - Electrical 42
  - Hydraulically 37
- Control plate 11
- Control unit 11
- Conversion 52
- Corrosion protection 25
- Cylinder 11

### D

- Danger 7
- Decommissioning 50
- Delivery contents 10
- Device description 11
- Dimensions 24, 34
- Direction of rotation 33
- Disassembling 50
  - Performing 50
  - Preparing 50
- Disposal 52
- Drive shaft 11

### E

- Environmental protection 52

### F

- Filling 30, 32, 44
- Flushing cycle 46
- Forklift truck 24
- Functional description
  - Auxiliary pump 12
  - Closed circuit 11
  - Control 13
  - High-pressure safeguarding 12
  - Pressure cut-off 12
  - Pump 12
- Functional test 46

### G

- General instructions 34

### H

- High-pressure side 11
- Hydraulic fluid 44

### I

- Identification 23
- Inspection 48
- Installation
  - On a gearbox 35
  - With coupling 35
- Installation conditions 27
- Installation position 29
  - Above-tank installation 31
  - Below-tank installation 30
- Instructions
  - General 7, 34

### L

- Lifting device 24
- Lifting strap 25
- Low-pressure side 11

**M**

Maintenance 48, 49  
Malfunction table 54

**N**

Name plate 23  
Neutral valve 12

**O**

Operation 47  
Operator's  
  Obligations 9  
Options  
  Neutral valve 12

**P**

Performance description 11  
Piston 11  
Port overview 39  
Product description 11

**Q**

Qualifications  
  Personnel 6

**R**

Recommissioning  
  After downtime 46  
Related documents 4  
Repair 49  
Retaining plate 11  
Ring screw 24  
Running-in phase 47

**S**

Safety instructions 6, 7  
Slipper pad 11  
Spare parts 49  
Storage 24  
Storage time 25  
Stroke piston 11  
Swashplate 11

**T**

Technical data 56  
Tightening torques 41  
Tools 50  
Transport 24  
  With lifting device 25  
  With ring screw 24  
Transport protection 36  
Troubleshooting 53

**U**

Use  
  Improper 6  
  Intended 6

**W**

Warning 7  
Warranty 8, 26, 37, 44, 52  
Weights 24



Bosch Rexroth AG  
Hydraulics  
Axial Piston Units  
Glockeraustraße 2  
89275 Elchingen, Germany  
Phone +49 (0) 73 08 - 82 0  
Fax +49 (0) 73 08 - 72 74  
info.brm-ak@boschrexroth.de  
[www.boschrexroth.com/brm](http://www.boschrexroth.com/brm)