

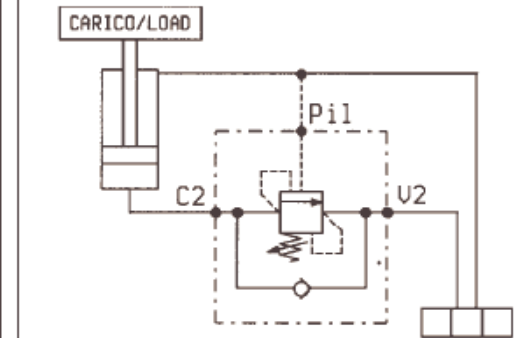

BILANCIAMENTO, SEMPLICE EFFETTO, SERIE "NBA"
PILOT ASSISTED, SERIES "NBA" OVERCENTRE

VBSO-SE-NBA

05.43.01 - X - Y - Z

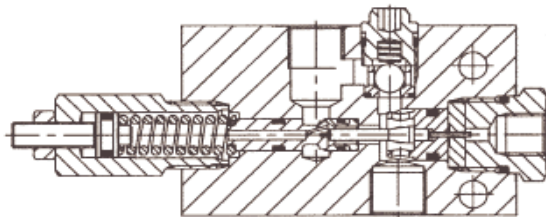
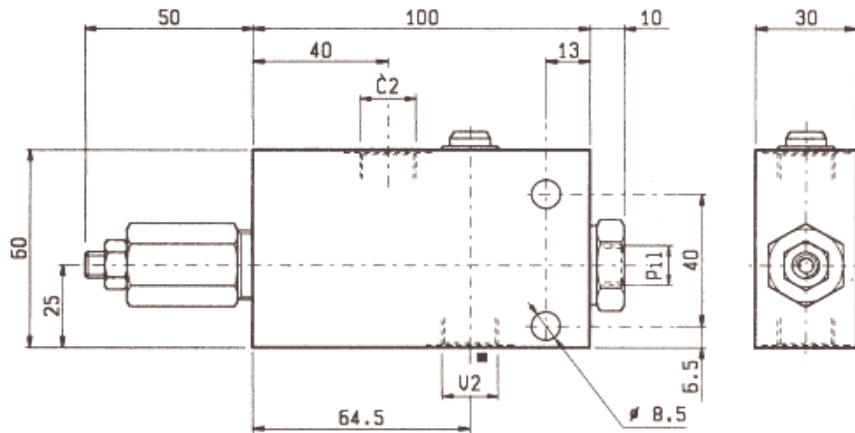

DATI TECNICI / TECHNICAL DATA

Pressione max. 350 bar
Max. pressure

Portata max. 40 l/min
Flow max.

Taratura della valvola: almeno 1.3 volte superiore alla pressione indotta dal carico

Pressure setting: at least 1.3 times the load induced pressure

Cappello per piombatura Codice/Ordering code
Sealing Cap 03.05.01.002

Peso 0.67 kg
Weight

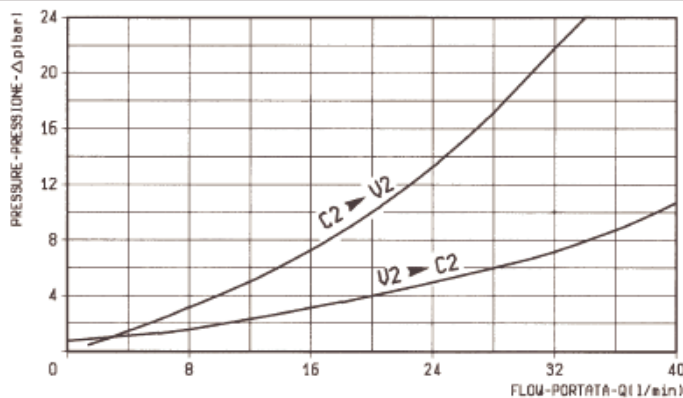

X RAPPORTO DI PILOTAGGIO PILOT RATIO

37 9.1 : 1

10 3.6 : 1

39 2 : 1

MOLLE / SPRINGS

Z	MOLLE / SPRINGS				
	Campo taratura min - max bar Adj. press. range bar	Incremento press. bar / giro vite Press. increase bar / turn	Taratura standard bar (Q = 5 l/min) Std. setting bar (made at 5 l/min)	Cod. ordinazione Ordering code	Colore Colour
20	60-210	50	200	03.51.01.075	verde green
35	100-350	88	350	03.51.01.059	giallo yellow

Y ATTACCHI / PORT SIZE

Y	ATTACCHI / PORT SIZE	
	V2-C2	PIL
02	G 3/8	G 1/4