

Motion control

VAA-B-SICN-ST-150

05.71.44 - X - 04 - Z

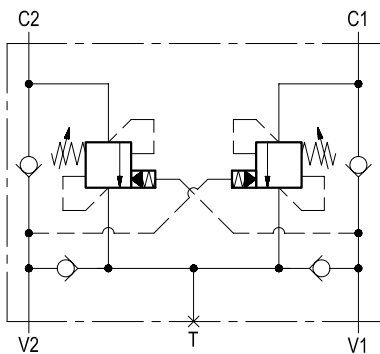
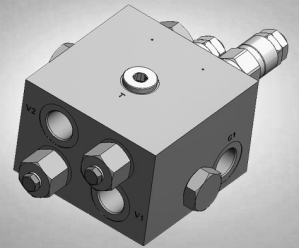

Description

It provides static and dynamic motion control by regulating flow and pressure IN and OUT of the hydraulic motor at ports C1 and C2. When installed close to the motor, it can stop runaway in case of hose failure. The check sections allow free flow into the motor and prevent reverse movement; the pilot assisted relief valves control the movement when pilot pressure is applied. A system of check valves allows cross line relief; an optional make-up port (T) allows to compensate for any volume change.

Technical data

Hydraulic

Operating pressure	bar (psi)	up to 210 (3000)
Max. flow	l/min (gpm)	120 (32)
Relief setting: at least 1.3 times the highest expected load.		

General

Manifold material	Aluminium	
Note: aluminium bodies are often strong enough for operating pressures exceeding 210 bar (3000 psi), depending from the fatigue life expected in the specific application. If in doubt, consult our Service Network.		
Weight	kg (lbs)	5.7 (12.5)
Fluid temperature range	°C (°F)	between -30 (-22) and +100 (212)
Other technical data	see data sheet RE 18350-50	

Performance

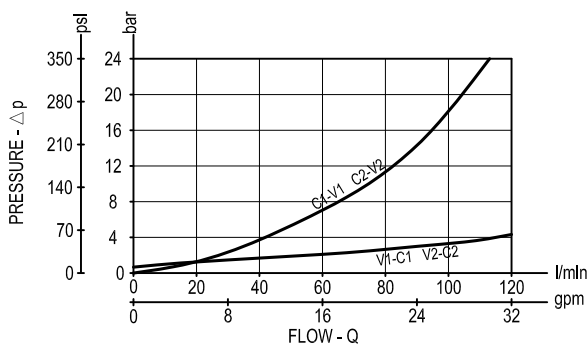

Note: for applications outside these parameters, please consult us.

Dimensions

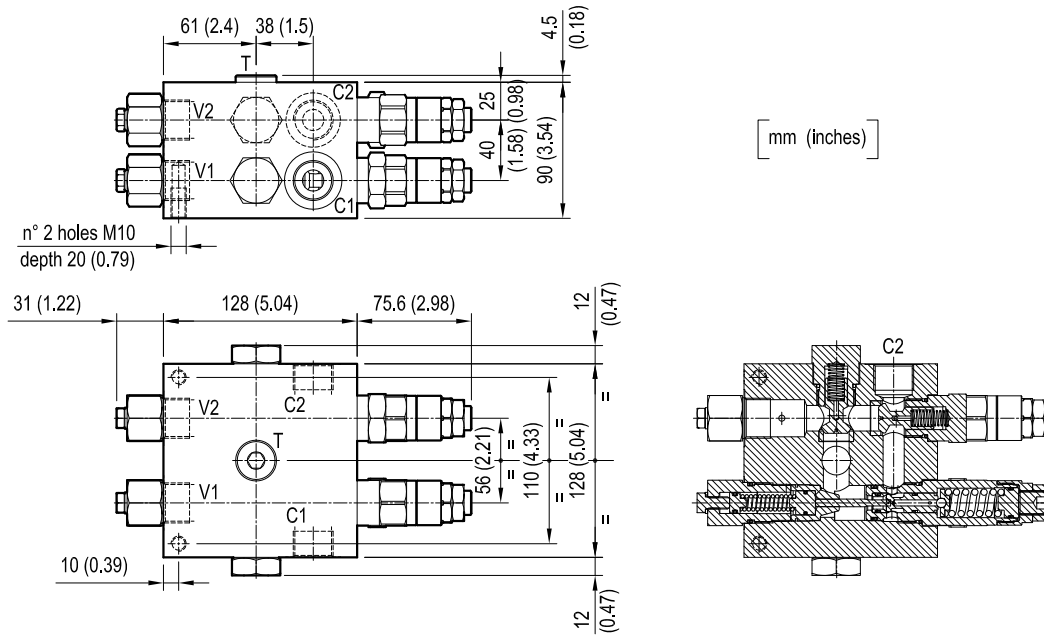

Ordering code

05.71.44 X 04 Z

Motion control	
Pilot ratio	
= 03	7.6:1
= 10	3:1

Port sizes	V1-V2	C1-C2	T
	G 3/4	G 3/4	G 1/2

	SPRINGS		
	Adj. pressure range bar (psi)	Pres. increase bar/turn (psi/turn)	Std. setting Q=5 (l/min.) bar (psi)
= 35	100-350 (1450-5000)	105 (1523)	150 (2200)

Type	Material number
05714403043500B	R930006932
05714410043500B	R930006955

Type	Material number