

Motion control, dual setting, with brake release port

VAA-B-SICN-PDRM-VF-250

05.71.47 - X - 05 - Z

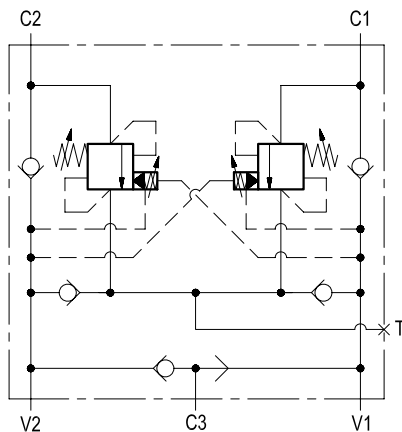
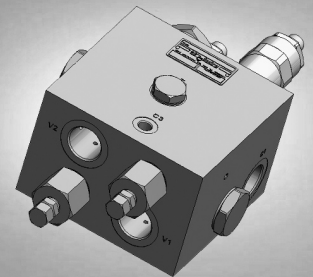

Description

It provides static and dynamic motion control by regulating flow and pressure IN and OUT of the hydraulic motor at ports C1 and C2. When installed close to the motor, it can stop runaway in case of hose failure. The check sections allow free flow into the motor and prevent reverse movement; the pilot assisted relief valves control the movement when pilot pressure is applied. The relief valves operate with 2-levels pressure setting, both adjustable: higher setting when flow is delivered to the motor, and lower setting when flow is discharged by the motor during stopping. A system of check valves allows cross line relief and an optional make-up port (T) allows to compensate for any volume change. Through port C3, a shuttle valve directs either V1 or V2 pressure to the spring actuated brake for brake releasing.

Technical data

Hydraulic

Operating pressure	bar (psi)	up to 210 (3000)
Max. flow	l/min (gpm)	200 (53)

Relief setting: at least 1.3 times the highest expected load.

The lower pressure setting (see table "SPRINGS") refers to flow from "C1" to "C2" (or "C2" to "C1"), and is adjustable through register "A" (see the drawing).

General

Manifold material	Aluminium	
Note: aluminium bodies are often strong enough for operating pressures exceeding 210 bar (3000 psi), depending from the fatigue life expected in the specific application. If in doubt, consult our Service Network.		
Weight	kg (lbs)	10.8 (23.8)
Fluid temperature range	°C (°F)	between -30 (-22) and +100 (212)
Other technical data	see data sheet RE 18350-50	

Performance

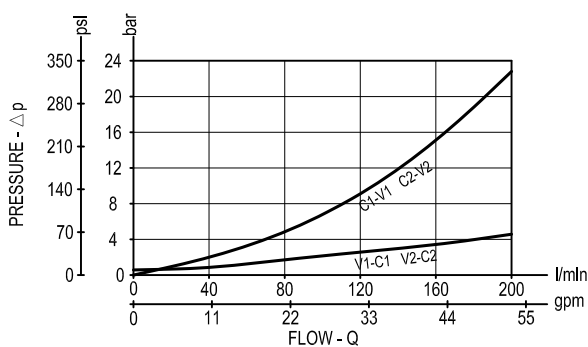

Note: for applications outside these parameters, please consult us.

Dimensions

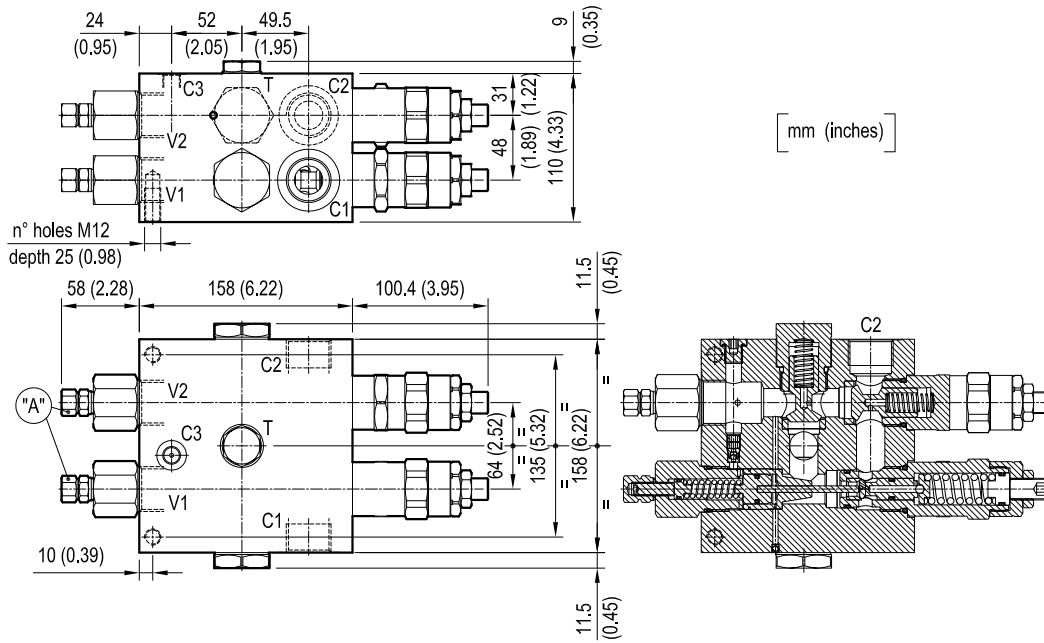

Ordering code

05.71.47 X 05 Z

Motion control, dual setting,
with brake release port

Pilot ratio

= 03 8:1

Port sizes	V1-V2	C1-C2	C3	T
	G 1	G 1	G 1/4	G 5/8

SPRINGS

	Adj. pressure range bar (psi)	Pres. increase bar/turn (psi/turn)	Std. setting Q=5 (l/min.) bar (psi)
= 35	100-350 (1450-5000)	62 (899)	300 (4350) 120* (1740*)

* Lower pressure setting.

Type	Material number
05714703053500B	R930006898

Type	Material number