

Flow regulator, 3-way, combination type, pressure compensated

VRFC3C

OM.42.03 - X - Y

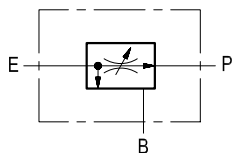

Performance

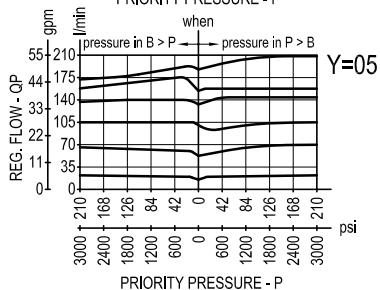
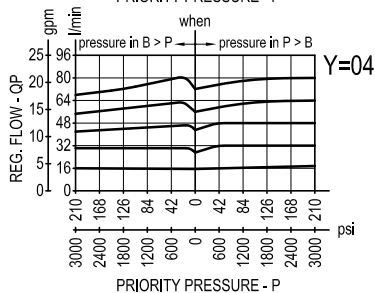
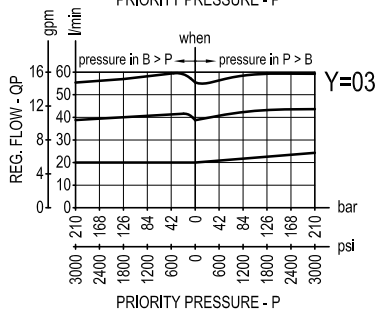
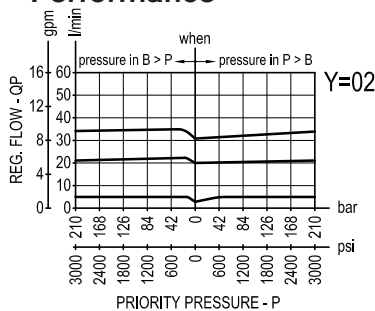

Description

A constant priority flow, regardless of system pressures, is established from E to P, while a minimum pressure differential of appr. 5 bar (70 psi) exists between the two ports. While the regulated priority flow from P is in the priority circuit, the flow supplied to E in excess of priority is by-passed to B port and can be sent to power other actuators. Priority flow can be varied from closed to the nominal maximum rating of the valve. Reverse flow from P to E is limited by the selected opening of the restrictor and is not pressure compensated. Reverse flow from B is not permitted.

Technical data

Hydraulic

Operating pressure bar (psi) up to 210 (3000)

QE = max inlet flow "E" port (see "Dimensions")

QP = max priority flow "P" port (see "Dimensions")

Flow range adjustment : 0 - 3 turns

General

Manifold material Aluminium

Note: aluminium bodies are often strong enough for operating pressures exceeding 210 bar (3000 psi), depending from the fatigue life expected in the specific application. If in doubt, consult our Service Network.

Weight see "Dimensions"

Fluid temperature range °C (°F) between -30 (-22) and +100 (212)

Other technical data see data sheet RE 18350-50

Note: for applications outside these parameters, please consult us.

Dimensions

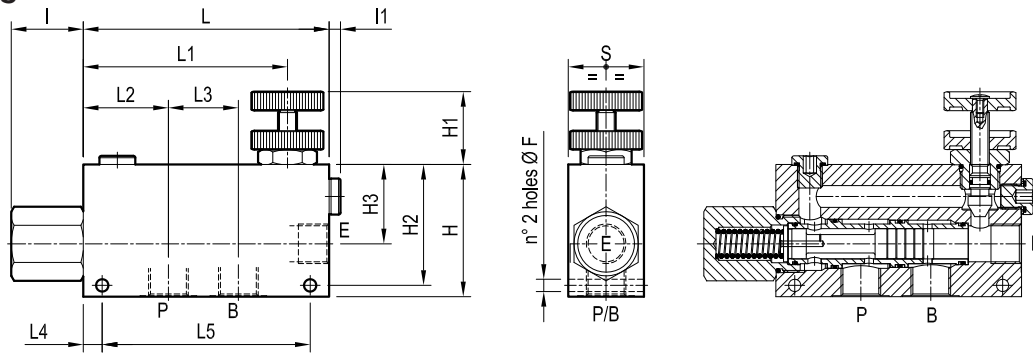

70 (2.76)	130 (5.12)	10 (0.39)	56.5 (2.22)	48 (1.89)	122.5 (4.82)	150 (5.91)	6 (0.24)	54 (2.13)	65 (2.56)	120 (4.72)	40 (1.58)	130 (5.12)	8.5 (0.34)	190 l/min 50 gpm	380 l/min 100 gpm	G 1	4.4 (9.7)
50 (1.97)	135 (5.32)	10 (0.39)	44 (1.73)	54 (2.13)	130 (5.12)	155 (6.1)	6 (0.24)	35 (1.38)	55 (2.17)	83 (3.27)	40 (1.58)	90 (3.54)	8.5 (0.34)	90 l/min 24 gpm	150 l/min 40 gpm	G 3/4	2.5 (5.5)
40 (1.58)	110 (4.33)	10 (0.39)	37 (1.46)	45 (1.77)	108 (4.25)	130 (5.12)	6 (0.24)	38 (1.5)	42 (1.65)	64 (2.52)	40 (1.58)	70 (2.76)	6.5 (0.26)	55 l/min 15 gpm	90 l/min 24 gpm	G 1/2	1.3 (2.87)
40 (1.58)	110 (4.33)	10 (0.39)	37 (1.46)	45 (1.77)	108 (4.25)	130 (5.12)	6 (0.24)	38 (1.5)	42 (1.65)	64 (2.52)	40 (1.58)	70 (2.76)	6.5 (0.26)	30 l/min 8 gpm	55 l/min 15 gpm	G 3/8	1.3 (2.87)
S	L5	L4	L3	L2	L1	L	I1	I	H3	H2	H1	H	F	QP	QE	Y	Weight kg (lbs)

[mm (inches)]

Ordering code

OM.42.03 X Y

Flow regulator,
3-way, combination type,
pressure compensated

Adjustments

= 70 Handknob and locknut



= 80 Screw and locknut



= 40 Graduated handknob



Port sizes	E - B - P
= 02	G 3/8
= 03	G 1/2
= 04	G 3/4
= 05	G 1

Type	Material number
OM4203700200000	R930004324
OM4203700300000	R930004325
OM4203700400000	R930004328
OM4203700500000	R930004329
OM4203800200000	R930004332
OM4203800300000	R930004333
OM4203800400000	R930004334
OM4203800500000	R930004336

Type	Material number
OM4203400200000	R930004317
OM4203400300000	R930004318
OM4203400400000	R930004319
OM4203400500000	R930004320